

MEDENUS

Gas Pressure Regulation



Cellular Gas Filter DF 100



Product information

EN

Table of Contents

Application, Characteristics, Technical Data	4
Application	4
Characteristics	4
Types of models / Options	4
Technical data	5
Structure and function	6
Installation example	6
Sectional view DN 25 / 50 / 80 / 100	6
Sectional view DN 150 / 200	7
Design of the Differential Pressure Gauge	8
Dimensions of the differential pressure gauge (mm)	8
Dimensions, Connection, and Weight	9
Types of Models / Options	10
Properties of Gases	10
Design	11
Performance diagram	11
Order Data	12
Contact	13
Notes	15



ATTENTION

Observe the following publications in relation to installation, start-up and maintenance:
DVGW - work sheets G 491 and G 600
Operating and Maintenance Instructions DF100

List of abbreviations and formula symbols

PS	Maximum allowable pressure	t	Temperature	AMSL	Above mean sea level
p_u	Inlet pressure	$p_{\bar{u}}$	Overpressure in bar		The "Normalnull" (German word for "mean sea level", abbreviated as "NN" or "N.N.") represented the defined zero level of the official reference height in Germany from 1879 to 1992
Δp	Pressure difference from inlet pressure to outlet pressure	p_{amb}	Ambient pressure		
		Q_n	Standard volumetric flow rate		
w_u	Gas inlet velocity	Q_b	Operating volumetric flow rate		
$\rho_{n\ Gas}$	Standard gas density				

Application, Characteristics, Technical Data

Application

Type DF 100 cellular gas filters are intended to separate gas impurities such as dust, rust, and other solids in gas-carrying lines at a defined point.

They are mainly used in gas systems and in front of such devices whose function is impaired by contamination.

Can be used as an equipment component on gas consumption facilities as defined in Regulation (EU) 2016/426.

These filters can be used for gases according to DVGW work sheet G 260/G 262 and for neutral non-aggressive gases. (other gases on request)

Characteristics

- Open-air model as standard
- Easily replaceable filter cartridge with hydrophobic filter medium
- High separation efficiency thank to optimized flow guidance
- Optionally with differential pressure gauge
(for electrical remote transmission, differential pressure gauge with limit switch)

Type of models / Options (see page 10)

- with differential pressure gauge
(for electrical remote transmission, differential pressure gauge with limit switch)
- Oxygen model ($p_u \leq 10$ bar)
- Hydrogen model
- Coating with epoxy resin in RAL colors



Cellular gas filter DF 100 DN 50



Cellular gas filter DF 100 DN 50 with differential pressure gauge

Preferred installation position

The cellular gas filter DF100 shall be installed in the pipeline preferably in vertical or horizontal position. An installation upside down is possible but not recommended. For all nominal widths, the direction of flow is indicated by an arrow on the housing.



Note: Observe the following documents in relation to installation, start-up, and maintenance:

- DVGW - work sheets G 491 and G 600
- Operating and Maintenance Instructions DF100

Technical data

Type	DF 100
Max. allowable pressure PS	16 bar
Nominal width	DN 25 / 50 / 80 / 100 / 150 / 200
Connection type	DIN PN 16 flanges ASME - ANSI B16.5 flanges Class 150 RF
Material	Housing - Aluminium Filter - Polyester-reinforced cellulose paper Seals - NBR
Corrosivity category	DIN EN ISO 12944-2 C1 to C5-I without additional coatings C5-M an epoxy resin coating is recommended (see page 10)
Temperature range (operating/ambient temperature)	- 20°C to + 60°C (optional - 40°C to + 70°C)
Filter area	DN 25 - 0.0510 m ² DN 100 - 0.9300 m ² DN 50 - 0.2430 m ² DN 150 - 2.5000 m ² DN 80 - 0.4500 m ² DN 200 - 3.0000 m ²
Filtration efficiency	Standard 99.9 % of the particle size > 2 µm *
Δp Reference value for new filter cartridge	Δp = 50 mbar at a gas inlet flow velocity of w _u = 20 m/s **
Δp Reference value for cartridge replacement	800 to 1,000 mbar
Δp_{max} Limit value for dirty filter cartridge	Δp _{max} = 2,000 mbar
Dust holding capacity	135 mg/cm ²
Function, strength, and tightness	DIN 3386, DVGW work sheet G 498 and DIN 30690-1
CE mark acc. to PED / PIN number	CE-0085CP0531
Ex protection	The mechanical parts of the device do not have any potential ignition sources of their own and therefore do not fall within the scope of ATEX 95 (94/9/EC). Electrical components fitted to the device comply with the ATEX requirements.

*) other filtration efficiencies on request

**) With a gas inlet flow velocity of 20 m/s, the gas velocity through the filter element is approx. 0.14 - 0.22 m/s depending on the nominal size. (In case of high dust formation, a significantly lower flow rate is recommended)

Structure and function

The gas flows through the inlet flange into the filter housing. The more than 100-fold increased filter area compared with the cross-section of the inlet flange reduces the flow rate accordingly. The dust particles entrained in the gas are retained by the filter element. The cleaned gas flows off through the outlet flange.

The filters mainly consist of the housing, the cover, and the filter cartridge. Taking off the cover for maintenance and replacement of the filter cartridge guarantees easy access. The filter cartridge consists of the filter basket and the filter element.

Depending on the application and the particle size to be separated, the filter cartridge to be used must have a suitable pore size.

The filter cartridge is sealed against the housing or against the hood by means of two sealing rings which are in large part integrated in the filter cartridge. The lid at the bottom of the filter allows convenient removal of any residues formed (dismounting dimension 40 mm). For this reason, the upright or horizontal mounting position is preferable. The nominal widths DN 150 and DN 200 are equipped in addition with an eye bolt M10.

Installation example

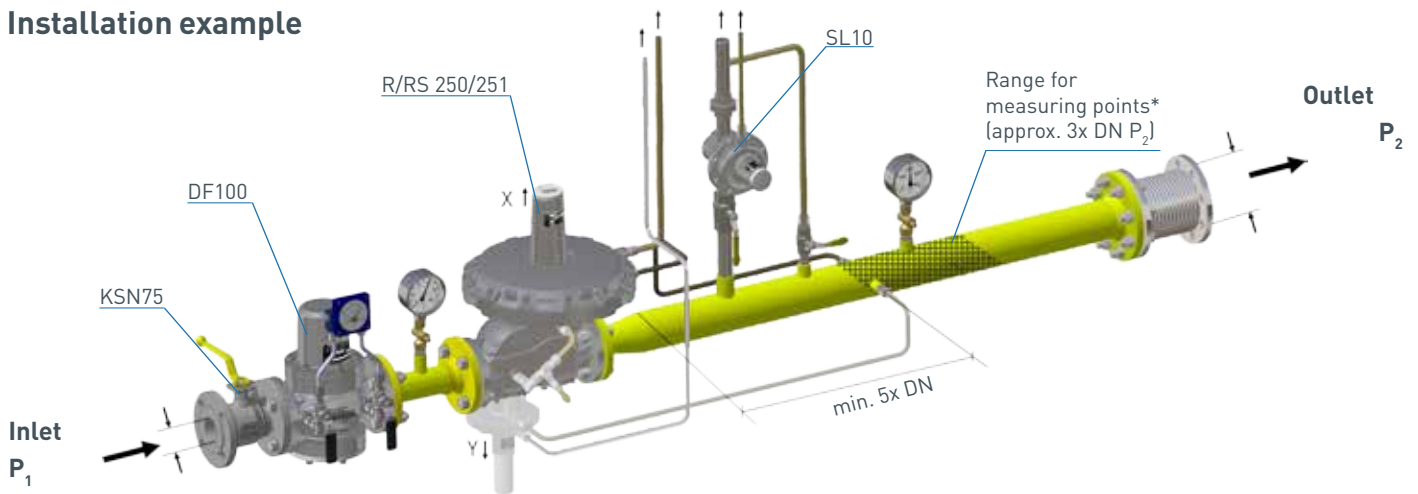

*) Recommended max. velocity at the measurement line port 25 m/s

Sectional view DN 25 / 50 / 80 / 100

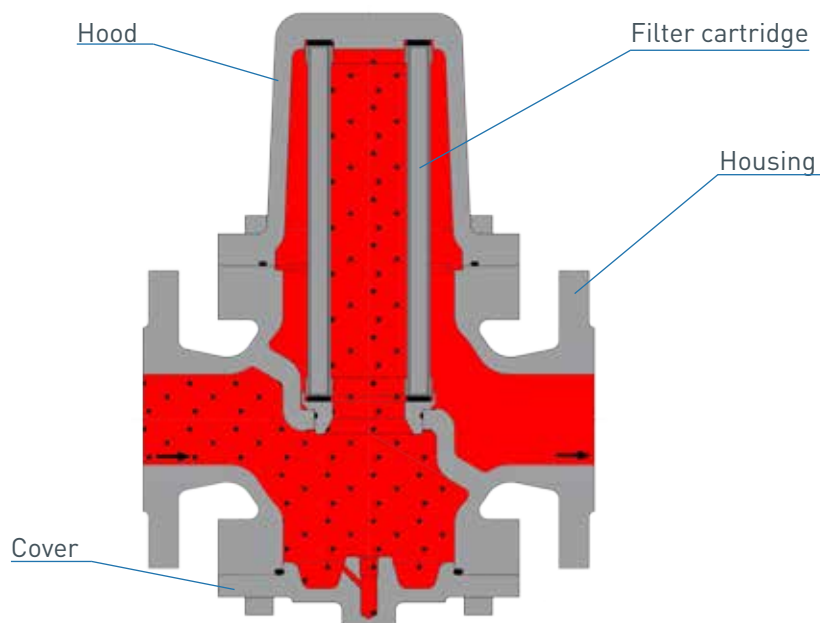

shown DN 50

Sectional view DN 150 / 200

(with spacer and eye bolt)

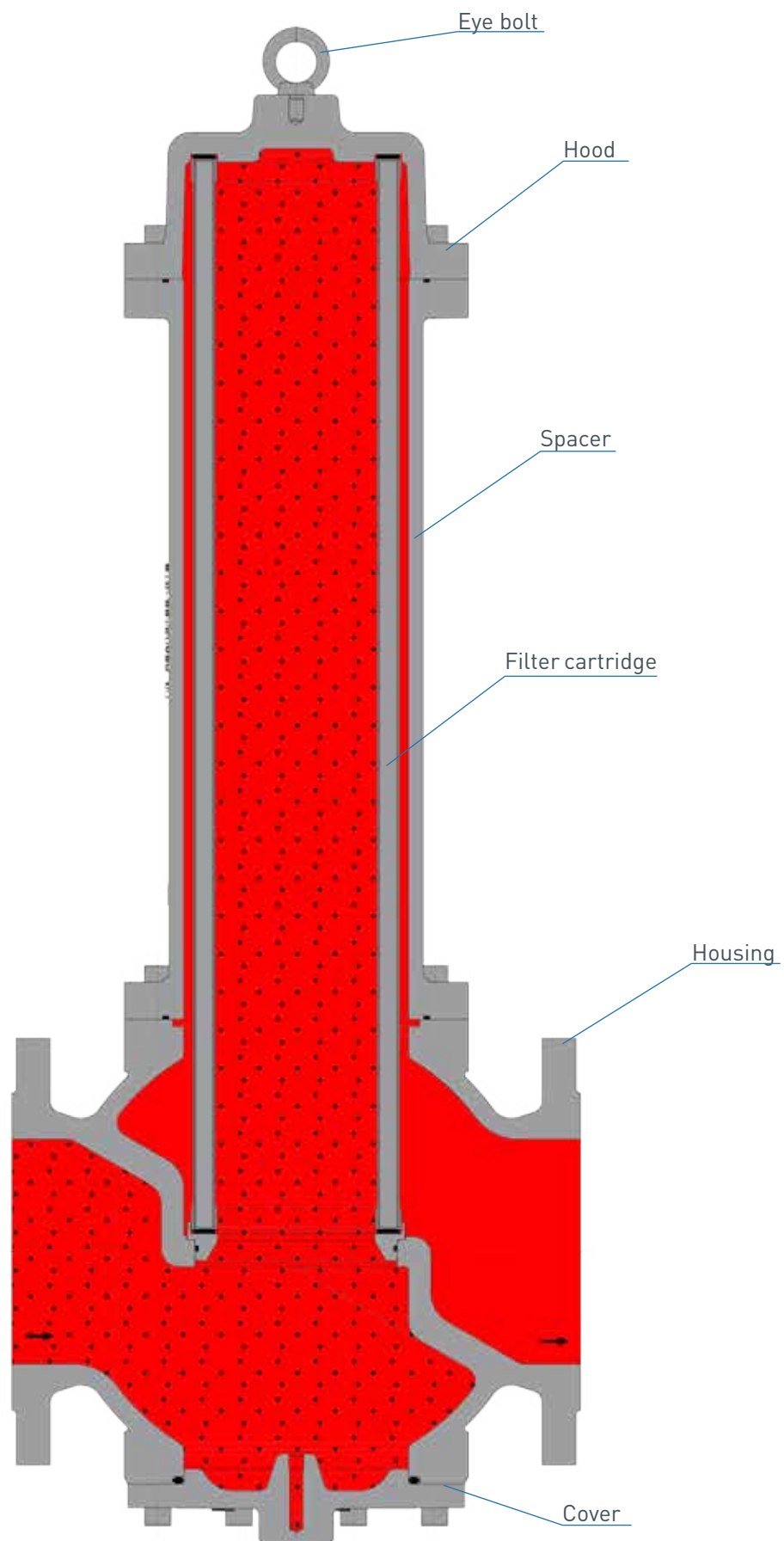

shown DN 150

Design of the Differential Pressure Gauge

DN 25 / 50 / 80 / 100 / 150 / 200

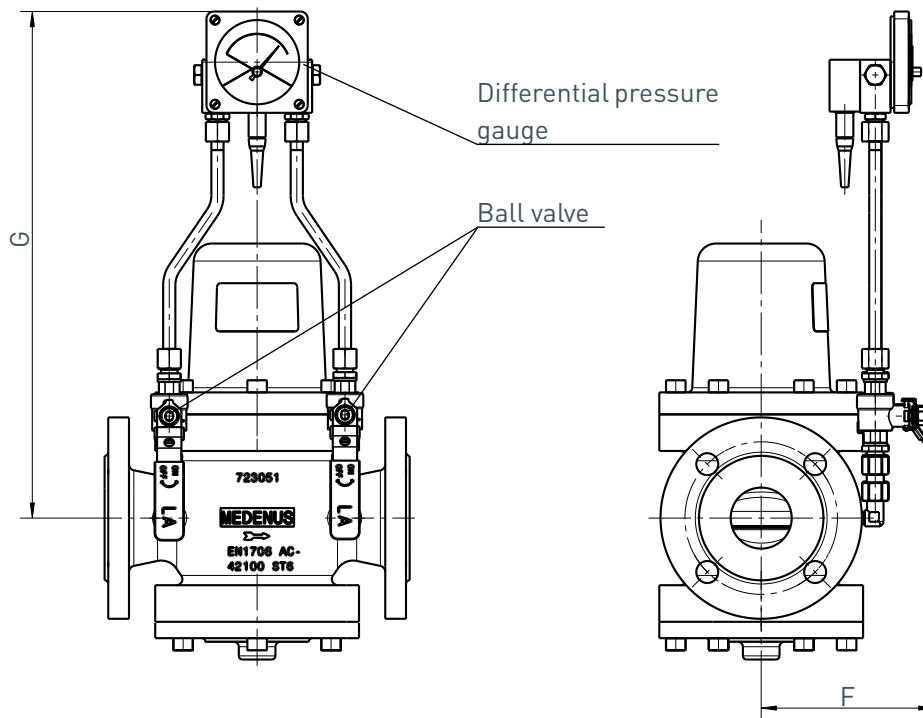

DN 50 PN 16 with differential pressure gauge with reed contact is shown
(ball valve in operating position)

In order to monitor the degree of soiling, all nominal widths can be equipped or retrofitted with a differential pressure gauge.

For the version with electrical remote transmission, a differential pressure gauge with reed contact is provided.

The differential pressure gauge can be mounted depending on the ordered flow direction of the filter.

On request, every connecting line is equipped with a ball valve.

Dimensions of the differential pressure gauge (mm)

Nominal width	G	F
DN 025	355	146
DN 050	415	141
DN 080	432	153
DN 100	452	171
DN 150		193
DN 200		234

Dimensions, Connection, and Weight

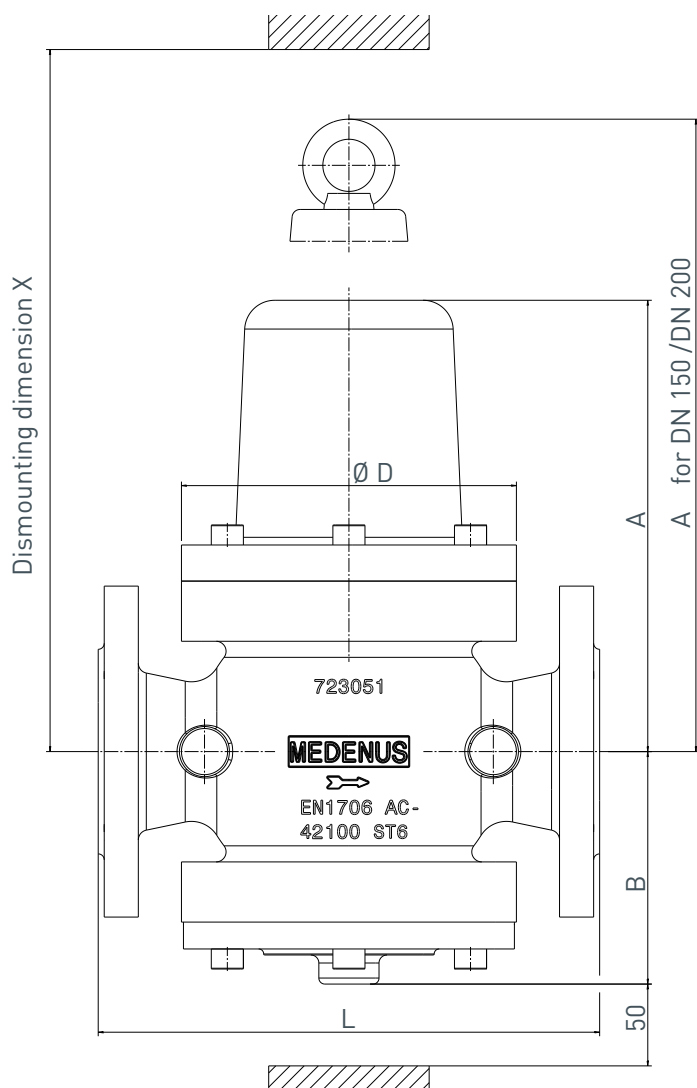

Dimensions	Nominal widths					
	DN 25	DN 50	DN 80	DN 100	DN 150	DN 200
A [mm]	102	225	317	404	817	954
B [mm]	80	116	138	188	195	225
D [mm]	92	167	167	200	230	280
L [mm]	160	250	280	350	380	420
X [mm]	192	350	512	546	905*	1040*
Weight [kg]	3.0	9.0	12.0	23.0	41.0	62.0
Volume of the pressure chamber (l)	0.6	2.7	4.8	12.6	25.4	46.6

- Connection for differential pressure gauge G 1/4"
- Eye bolt for DN 150 / DN 200 M10
- Type of connection (standard): on both sides DIN flange PN 16

*) we recommend: DN 150 - 1230 mm / DN 200 - 1475 mm

Types of Models / Options

Differential pressure gauge DP 900

The differential pressure gauge DP 900 has been designed to monitor differential pressures. It is mainly used in gas supply systems such as gas transfer, measurement and regulation stations (for all gases). Helium version with special leakage test available upon request. It is also used in air supply systems, for example on filters, and air treatment systems. Especially in systems that do not contain magnetic particles.

DDM without reed contact



DDM with reed contact

Epoxy resin coating in RAL colors

To protect the filter from external influences, starting from a corrosivity category C5-M we recommend an epoxy resin coating.



Types of models

Oxygen model O₂ (p_u ≤ 10 bar)
 Hydrogen version H₂ (with helium leak test)

The Medenus gas pressure regulators are suitable for use with hydrogen as a medium up to a proportion of 100%. Further information can be found in the special edition (10/2019) of gwf Gas+Energie and on our homepage at (www.medenus.de)



Properties of Gases

- for natural gas (ρ_n = 0.83 kg/m³; t = 15°C)
- f - natural gas conversion factor- L

Gas	f	Hs,n [kWh/m ³]	Gas	f	Hs,n [kWh/m ³]
Acetylene	0.84	16.25	Sewage gas	0.84	
Ammonia	1.04	4.83	Carbon monoxide	0.81	3.51
Butane	0.55	37.23	Carbon dioxide	0.65	-
Chlorine	0.51	-	Air	0.80	-
Landfill gas	approx. 0.80		Methane	1.08	11.06
Natural gas L	1.00	9.77	Propane	0.64	28.03
Natural gas H	1.03	11.45	Oxygen	0.76	-
Ethane	0.78	19.55	Sulphur dioxide	0.53	-
Ethylene	0.97	16.516	Nitrogen	0.81	-
Mine gas (30% CH ₄)		0.86	Hydrogen	3.04	13.43
Helium	2.15	-			

Design

Performance diagram

(pressure loss when not contaminated)

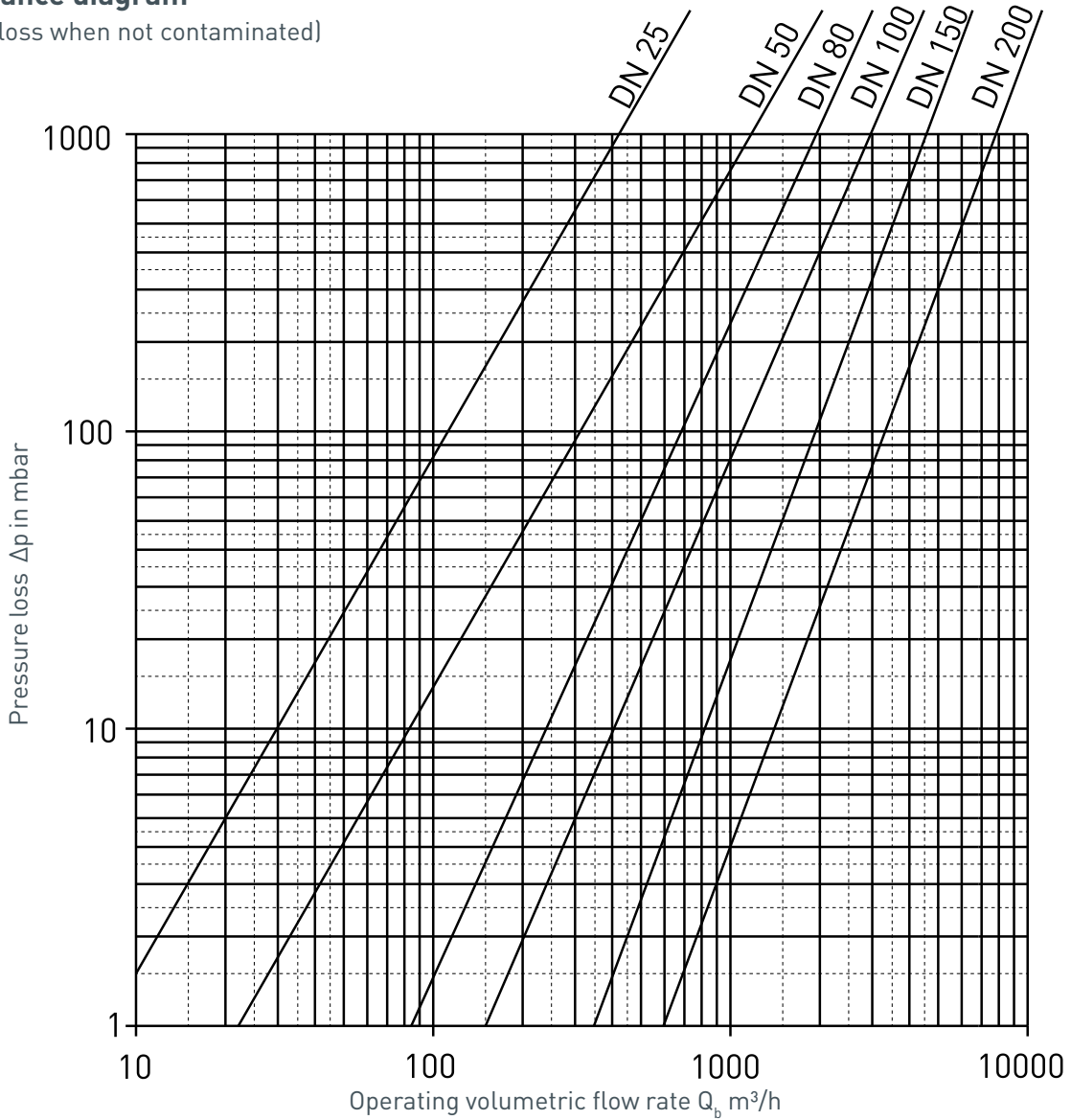

Recommended maximum operating volumetric flow rate Q_b

DN 025	DN 050	DN 080	DN 100	DN 150	DN 200
100 m³/h	400 m³/h	1000 m³/h	1700 m³/h	3800 m³/h	6800 m³/h

Example: for $Q_b = 100 \text{ m}^3/\text{h}$ and DN 25: $\Delta p_{\text{diagram}} = 80 \text{ mbar}$

Operating volumetric flow rate m^3/h and standard volumetric flow rate m^3/h :

$$Q_b = \frac{1.01325 \cdot Q_n \cdot (t + 273.15)}{273.15 \cdot (p_u + p_{\text{amb}})}$$

$$Q_n = \frac{273.15 \cdot Q_b \cdot (p_u + p_{\text{amb}})}{1.01325 \cdot (t + 273.15)}$$

AMSL [m]	0	200	500	1000	2000	4000	6000	8000	11000
P_{amb} [bar]	1.01315	0.989	0.955	0.899	0.795	0.616	0.472	0.356	0.226

Note

The values apply to natural gas $L \rho_{n \text{ gas}} = 0.83 \text{ kg}/\text{m}^3$ and $t = 15 \text{ }^\circ\text{C}$

When using other types of gas, the pressure loss is calculated to give $\Delta p = \rho_{n \text{ gas}} / 0.83 \cdot \Delta p_{\text{diagram}}$

Order Data

Example:

Cellular gas filter: DF100/050/left/D/R/T/WAZ/So

Order selection	Order code:	DF100	050	-	left	D/R	T	WAZ	So
Designation									
Type									
DF100	DF100	DF100							
DN - Nominal width	Table p. 12		050						
Flange model									
PN 16	-			-					
Class 150	C								
Direction of flow									
Right (from left to right)	-								
Left (from right to left)	left				left				
Differential pressure gauge	Fig. S. 10								
without differential pressure gauge	-								
with differential pressure gauge without reed contact	D/-								
with differential pressure gauge with reed contact	D/R					D/R			
Temperature range									
-20°C to +60°C	S								
-40°C to +70°C	T						T		
Acceptance test certificate to EN 10204/3.1									
without acceptance test certificate	-								
with acceptance test certificate	WAZ							WAZ	
Special model									
- Coating with epoxy resin in RAL colors									
- Hydrogen model H ₂	So								So
- Oxygen model O ₂									

In every selection group, only one option can be selected in each case.

DN - Nominal width

Type	025	050	080	100	150	200
DF100	X	X	X	X	X	X

Contact

If you want to know more about solutions from MEDENUS for the gas industry, please contact your local contact person or go to our internet site at www.medenus.de



Management

Alexander Christiani

Phone: +49 (0) 2761 / 82788-18
Fax: +49 (0) 2761 / 82788-9
E-mail: a.christiani@medenus.de



Head of Inside Sales Department

Manuel Schepp

Phone: +49 (0) 2761 / 82788-20
Fax: +49 (0) 2761 / 82788-9
E-mail: m.schepp@medenus.de



Head of Sales & Marketing

Franz Feichtner

Phone: +43 (0) 7227 / 211-17
Fax: +49 (0) 2761 / 82788-9
Mobile phone: +49 (0) 151 / 51002711
E-mail: f.feichtner@medenus.de



Inside Sales Department

Stefanie Müller

Phone: +49 (0) 2761 / 82788-13
Fax: +49 (0) 2761 / 82788-9
E-mail: s.mueller@medenus.de



Inside Sales Department

Natallia Kadyrka

Phone: +49 (0) 2761 / 82788-11
Fax: +49 (0) 2761 / 82788-9
E-mail: n.kadyrka@medenus.de

Trade representation worldwide
medenus.de/de/kontakt.html



MEDENUS

Gas-Druckregeltechnik GmbH

Im Langen Feld 3
D-57462 Olpe
Phone: +49 (0)2761 82788-0
Fax: +49 (0)2761 82788-9
E-mail: info@medenus.de
Internet: www.medenus.de



THE MEDENUS PLUS

10 reasons for good business relations

1. Consultancy expertise and quality standards developed over decades
2. Broad and proven standard range of feedback controllers
3. Modern, fast and efficient production for series products and for individual orders
4. Customer-specific design of pressure regulators and vacuum regulators and special designs
5. Guaranteed deadline compliance with a delivery deadline guarantee
6. Fast response time in all matters
7. Sufficiently large parts storage for production and spare parts
8. Customer-specific theory & practice training courses
9. Modular design right across the entire product range to facilitate optimized handling of spare parts
10. Made in Germany

In the download area of our homepage, this document is available in different languages. You can use the following QR codes and links to go directly to this document in your language.



Deutsch:

http://medenus.de/files/upload/downloads/DF100/Pi_DF100_de.pdf



English:

http://medenus.de/files/upload/downloads/DF100/Pi_DF100_en.pdf

Notes

.....

.....

.....

.....

.....

.....

.....

.....

.....

.....

.....

.....

.....

.....

.....

.....

.....

.....

.....

.....

.....

.....



MEDENUS Gas-Druckregeltechnik GmbH

Phone +49 (0)2761 82788-0

Fax +49 (0)2761 82788-9

Im Langen Feld 3 / D-57462 Olpe

info@medenus.de

www.medenus.de

EN