

MEDENUS

Gas Pressure Regulation



Gas pressure regulator R 50



Operating and Maintenance Instructions

EN

Table of Contents

1 General Information	4
1.1 Warranty and Liability	4
1.2 Symbols, Notes	5
1.3 Terms, Abbreviations	5
2 Safety Instructions	6
2.1 Hazards of Handling the Device	6
2.2 Personnel Requirements	6
2.3 Country-Specific Requirements	6
2.4 Handover of the Operating and Maintenance Instructions	6
2.5 Safety in Operation	7
2.6 What To Do in Case of Danger	7
3 Responsibility of the Operator	7
4 Transport, Storage and Packaging	8
4.1 Transport	8
4.2 Storage	8
4.3 Packaging	8
5 Mounting and Commissioning	9
5.1 Safety Instructions and Preparation	9
5.2 Mounting	10
5.3 Leakage Test (Test for External Leakage)	11
5.4 Initial Commissioning / Recommissioning	12
5.5 Decommissioning	13
6 Maintenance	13
6.1 Maintenance Plan	13
6.2 Maintenance Procedure	14
6.3 Table of Screw Tightening Torques M_A	14
6.4 Lubricants Table	14
7 Troubleshooting	15
7.1 Safety Relief Valve	15
8 Replacement and Disposal	16
9 Spare Parts	16
9.1 Parts for Maintenance Work	16
O-Rings and Sealing Rings	16
Valve Plate / Diaphragm	16
9.2 Spare Parts Drawing SL10	17
10 Declaration of Conformity	18
11 Notes	19

1 General Information

The personnel entrusted with installation, operation or maintenance of the safety relief valve must have completely read and understood beforehand the following documents:

- **Safety Relief Valve R 50 Product Information**

The product information contains technical data, dimensions and a description of the design and the mode of operation.

- **Safety Relief Valve R 50 Operating and Maintenance Instructions**

This document allows safe and efficient handling of the device and contains information on assembly, commissioning, maintenance, troubleshooting, and repair according to regulations.

It is an integral part of the scope of delivery of the device, must be kept in close proximity of the device and must be readily accessible to personnel at any time.

The basic requirement of safe operation is compliance with all safety instructions and guidelines specified in these instructions. Accordingly, the information and instructions must be observed when working on the device or on the gas line. In addition, the local occupational safety regulations and the general safety regulations for the application range of the device shall apply.

The figures in these instructions are provided for basic understanding and may differ from the actual design.

The contents in these instructions are protected by copyright. They may be used as part of operating the device. Any other use and / or reproduction is not permitted without prior authorization by the MEDENUS Gas-Druckregeltechnik GmbH.

1.1 Warranty and Liability

Claims under warranty or liability for personal injury and material damage are generally void, **if one or several of the following conditions are not observed:**

- Work on the device during the warranty period may only be performed in consultation with the manufacturer
- Designated use of the device in accordance with the established conditions of use
- Proper installation, commissioning, operation and maintenance of the device
- Operation of the device with properly installed and functioning safety devices only
- Operating and maintenance instructions of the device or of the system
- Observance of the maintenance instructions
- Properly performed repairs
- Supply lines without defects
- The use of original MEDENUS® spare parts and lubricants listed in these instructions or
- Force majeure

It is generally prohibited

- to perform constructive modifications on the device
- to keep using the device despite the detection of a defect

1.2 Symbols, Notes

The instructions contain safety instructions marked with symbols to indicate possible consequences in case of non-observance:

This combination of symbol and signal word indicates a potentially hazardous situation which may result in light injuries, damage to the device, the breakdown of the system, and material or environmental damage if not avoided.



NOTICE

This combination of symbol and signal word indicates an imminent hazardous situation, resulting in death or serious injuries if not avoided.



DANGER

This signal word highlights useful tips, recommendations, and information for efficient and trouble-free operation.

Note

1.3 Terms, Abbreviations

Terms and abbreviations are explained below:

ATC	Acceptance test certificate	SSV	Safety shut-off valve
DN	Nominal width	SRV	Safety relief valve
GPR	Gas pressure regulator		
MOP	Maximum operating pressure in a system		

2 Safety Instructions

National accident prevention regulations and the system operator's safety regulations are not superseded by these operating and maintenance instructions and must be taken into consideration with priority (in Germany, see, among others, DVGW Code of Practice G 600, G 459/II, G 491 and G 495)

When performing work on the device, the current general and specific safety regulations must be observed.

The application limits of the device with respect to the medium, operating pressure and operating temperature can be found on the type plate affixed to the device or on the acceptance test certificate.

Using the device under different operating conditions must be agreed upon in consultation with MEDENUS Gas-Druckregeltechnik GmbH.

The mechanical components of the device do not have any potential ignition sources of their own nor any hot surfaces and are thus not within the scope of 2014/34/EU (ATEX). The electronic accessories used comply with the ATEX requirements.

2.1 Hazards of Handling the Device

MEDENUS® devices conform with current standards and directives, the recognized technical rules and the recognized safety rules.

However, improper use can result in hazards to the user or to third parties. This can also result in damage to the device or to the system.

This is why the device may only be used:

- in accordance with its designated use,
- in perfect condition
- while observing the notes given in these operating and maintenance instructions, and inspection and maintenance regulations, which apply to the functioning and safety of the overall system.

Malfunctions or faults must be eliminated immediately.

2.2 Personnel Requirements

The device may only be mounted by qualified personnel.

Only authorised personnel in possession of the required qualification is allowed to perform settings or repairs on the device.

2.3 Country-Specific Requirements

The rules and regulations applicable at the place of use with respect to:

- gas lines, installation of the gas system
- gas supply
- work on the gas system
- accident prevention must be observed and complied with.

2.4 Handover of the Operating and Maintenance Instructions

The supplier of the system shall hand over these operating and maintenance instructions to the operator of the system no later than during commissioning and training of the operating personnel with the reminder to carefully store these instructions.

2.5 Safety in Operation

The device may only be used when all protective devices on the device or in the system are fully functional.

At least once a year, the device must be inspected for externally visible damage and for proper functioning by a representative of the manufacturer or by a qualified person.

A more frequent inspection may become necessary, depending on the system conditions.

2.6 What To Do in Case of Danger

Information on what is to be done in case of danger and in case of accidents can be found in the respective operator's or specialist company's work instructions.

3 Responsibility of the Operator

Operator An operator is a person who operates the device himself for commercial or economic purposes or hands it over to a third party for use / application and is legally responsible for the safety of the user, personnel or third parties.

Operator's obligations The device is used in the industrial sector. Accordingly, the operator of the device is subject to the legal obligations concerning occupational safety. In addition to the safety instructions contained in these instructions, the established maintenance intervals must be observed, taking into account the respective national standard (alarm and hazard prevention plan).

In particular, the following applies:

- The operator is obliged to perform work on MEDENUS® devices during the warranty period only after consultation with the manufacturer. Otherwise the claims under warranty will become void.
- The operator must obtain information on the current occupational safety regulations and determine additional hazards resulting from the special work conditions at the place of use of the device in a risk assessment. The operator must implement them in the form of operating manuals for operating the device.
- During the entire time of use of the device, the operator must check whether the operating manuals drawn up by him conform to the current state of the regulations and, if necessary, adapt them.
- The operator must clearly regulate and define the responsibilities for installation, operation, troubleshooting, maintenance, and cleaning.
- The operator must ensure that all persons handling the device have read and understood these instructions. In addition to that, he must train the personnel at regular intervals and inform it about the dangers.
- The operator must make available to the personnel the required protective equipment and oblige them to wear the required protective equipment.
- Moreover, the operator is responsible for the device always being in technically perfect condition.

Therefore, the following applies:

- The operator must make sure that the maintenance intervals described in these instructions are observed.
- The operator must have all safety devices checked regularly for functioning and completeness.

4 Transport, Storage and Packaging

4.1 Transport

Note

The device must be handled carefully and secured against impacts and knocks. In case of transport damage, we will require the following information from the type plate affixed to the device:

- Type of device
- Device model
- Year of construction / fabrication number

4.2 Storage

Equipment and spare parts must be stored under the following conditions:

- Do not store outdoors.
- Store in a dry and dust-free location.
- Store on a flat surface.
- Do not expose to aggressive media.
- Do not expose to ozone or ionizing radiation.
- Do not store adjacent to direct heat sources.
- Avoid mechanical vibrations.
- Storage temperature: 0 to 25°C.
- Relative humidity: < 55 %.

Spare parts:

- Components susceptible to corrosion must be provided with a suitable preservative.
- Do not store O-rings and seals for more than 7 years even if stored properly.
- Spare parts must be stored in their original packaging until use.

Storage period for devices:

- Storage of the device for up to one year:
Store the safety relief valve in its original packaging and original condition at the time of supply. All protective caps of the device must remain mounted.
- Storage of the device for more than 1 year (e.g. as a spare device):
Store the device in its original packaging and original condition at the time of supply and check it for damage once a year. Check the housing surface for dirt, damage and corrosion. If necessary, clean all external parts. After 7 years, all O-rings and seals must be replaced.

4.3 Packaging

- The individual packaged items have been packaged in view of the transport conditions to be expected.
- The symbols on the packaging must be observed during transport and storage.
- Only environmentally-friendly materials have been used for packaging.
- The packaging is designed for protecting the individual components from transport damage, corrosion and other damage until mounting. This is why the packaging must not be destroyed and only removed just prior to mounting.

5 Mounting and Commissioning

5.1 Safety Instructions and Preparation

Prior to starting work on pressurised components:

- Close all connections to the gas line.
- Depressurise all pressurised components. Also discharge residual energies.
- Defective components that are subject to pressure in operation must be replaced immediately by a suitable qualified person.

DANGER



Prior to starting work, ensure sufficient clearance for mounting.

Before installing the device, check whether the performance data (type plate) and the scope of delivery coincide with the order or the system data, i.e., make sure that the provided devices are suitable for their intended purpose. In particular, the inlet pressure of the system must be lower than the maximum allowable pressure of the device or the system must be declared to be differential pressure-resistant.

Note

A direct contact of gas valves and fittings, i.e., the control system, with hardening masonry, concrete walls or floors is not allowed. Provide suitable supports, working materials, and protective equipment. Take into account the minimum clearances for maintenance as stated in the product information. Before installing the device in the pipeline, check whether a shut-off device that interrupts the gas flow supply to the device has been mounted upstream of the device to be installed.

Note

Prior to commissioning, make sure that all installation work has been carried out and completed in accordance with the data and information given in these instructions and that no unauthorised persons stay in the danger zone.

DANGER



5.2 Mounting

- Install the safety relief valve (item 5.09) without twisting the pipeline. Make sure to observe the direction of flow, i.e., the arrow on the housing must point in the direction of flow.
- All breather lines (item 5.04) must be vented to the outside atmosphere.
- Breather lines (item 5.04) may not be required if breather valves are being used.

Note

Note

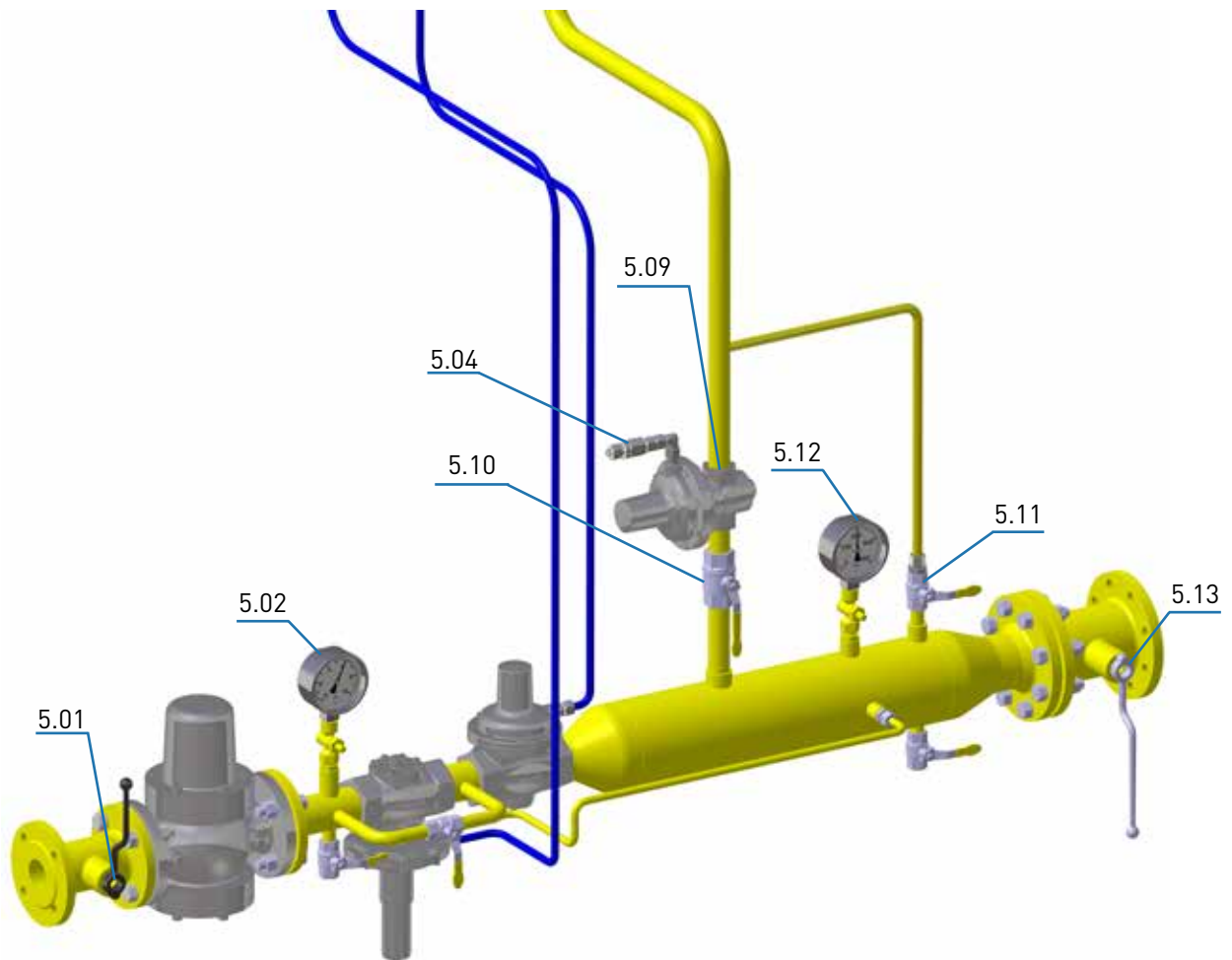

5.3 Leakage Test (Test for External Leakage)

The devices are subjected to a strength and leakage test ex works at MEDENUS Gas-Druckregeltechnik GmbH.

The leakage test in the fully assembled system must be performed prior to commissioning and following maintenance work.

For the external leakage test in the fully assembled system, the following applies:

For Germany:

According to DVGW Code of Practice G 491, the fully assembled system must be subjected to a leakage test with air or an inert gas at the installation site, using 1.1 times the maximum operating pressure of the system (MOP).

An exception is the room between the actuator installed in the gas pressure regulator and the first shut-off valve on the outlet side. This room must be checked using the a test pressure corresponding to the maximum permissible pressure in the system in case of a malfunction (1.1 MOP_d). In this test, all detachable connections must be checked using a foaming agent.

For other countries:

The relevant national and international standards shall apply.

Procedure

- Close the ball valves upstream of the valves and fittings (item 5.01).
- Close the downstream shut-off devices (item 5.13) (ball valves, solenoid or pneumatic valve).
- Depressurise the system (item 5.11).
- Connect the testing device to measuring points upstream and downstream of the gas pressure regulator (items 5.02 / 5.12).
- Test the tightness of the safety relief valve (item 5.09) until the response pressure is reached and then close the line upstream of

the SRV (item 5.10).

- Always increase the test pressure slowly and steadily.

While doing so, you must ensure:

Pressure in outlet chamber (item 5.12) \leq Pressure in inlet chamber (item 5.02)

Pressure build-up always from the inlet side (inlet chamber)

Pressure reduction always from the outlet side (outlet chamber)

- After leakage test:
Open the ball valve in the SRV line (item 5.10) again.

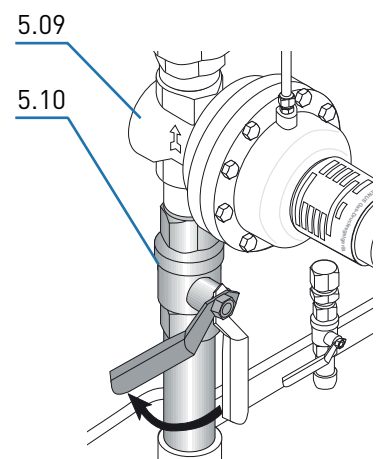

Note

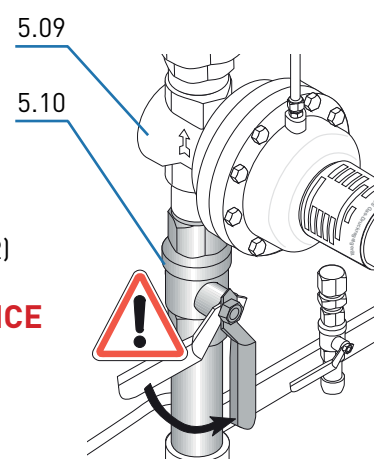

5.4 Initial Commissioning / Recommissioning

Initial commissioning of the system components shall be carried out by the operator. For commissioning, please refer to the documents listed under item 1 "General Information" and the system operator's work instruction.

The devices delivered by MEDENUS Gas-Druckregeltechnik GmbH are factory-set to the operating data specified by the customer. This data is listed on the Acceptance Test Certificate (ATC)* and the type plate.

Prior to commissioning of the system, a functional test must be performed on the gas pressure regulator (GPR), if applicable, and the safety shut-off and safety relief valves.

Procedure

- Close the ball valves upstream of the valves and fittings (item 5.01).
- Close the downstream shut-off devices (item 5.13) (ball valves, solenoid or pneumatic valve).
- Depressurise the system (item 5.11).
- Close venting ball valve (item 5.11).
- Slowly open ball valve upstream of the valves and fittings (item 5.01).

If the inlet shut-off device is equipped with a bypass, the latter must be slowly opened for pressure compensation as step 1. This is followed by slowly opening the inlet shut-off valve. The same is true of the outlet shut-off valve.

- Check the inner leakage of the SSV (item 5.06) by reading the pressure gauge installed downstream of the GPR (item 5.12).
- Unscrew the sealing cap (item 5.15) of the safety shut-off valve (SSV).
- Perform pressure compensation via the SSV by pulling at the pull knob (item 5.14) and allow the SSV to engage.
- A closing pressure corresponding to the set value is established on the GPR.

An SSV with underpressure shut-off can only be engaged if the pressure at the measuring point exceeds the set value by at least the re-engagement differential.

*) Acceptance Test Certificate (ATC) available optionally

5.5 Decommissioning

For decommissioning, please refer to the documents listed under item 1 "General Information" and the system operator's work instruction.

Procedure

- Slowly close the outlet shut-off valve (item 5.13) or
- Slowly lower the outlet pressure via the setpoint setting screw until the reserve rail takes over the gas supply or
- Slowly raise the setpoint of the reserve rail until the operating rail is disabled.
- Close the ball valves upstream of the valves and fittings (item 5.01).
- Depressurise the system (item 5.11).
- Close venting ball valve (item 5.11).

6 Maintenance

6.1 Maintenance Plan

The maintenance regulations of the system manufacturer must be observed. The following sections describe the maintenance work required for optimal and trouble-free operation of the device.

If increased wear is detected during regular inspections, the required maintenance intervals must be shortened in accordance with the actual wear.

For any questions on maintenance work and intervals, please contact the manufacturer.

The intervals for monitoring and maintenance work are strongly dependent on the operating situation and the condition of the gas. This is why no fixed intervals can be given. For Germany, it is recommended to observe initially the maintenance periods according to the data given in DVGW Code of Practice G 495. For each system, this must be followed by determining the maintenance interval independently on a medium-term basis.

During maintenance work, the components must be cleaned and subjected to a thorough visual inspection. This is also necessary if irregularities in the operating behaviour have been detected during operation or during functional tests. The check must cover the elastomers in particular.

Damaged parts and O-rings dismantled during dismantling must be replaced with new ones.

It is recommended to stock the parts listed in chapter 9.1 on page 16 for maintenance work.

Interval	Maintenance activities	Personnel
When required	Replacing O-rings	Qualified person
	Replacing diaphragms	
	Replacing the valve plate	
	Replacing sealing rings for the connections of the breather lines	

6.2 Maintenance Procedure

The maintenance procedure is described in detail step-by-step in our video tutorial and our pictorial descriptions. Instructions for our products can be found in the download area of our website. Should you have any problems, please feel free to contact us directly.

If components have been removed, make sure they are mounted correctly, reinstall all fastening elements and observe the screw tightening torques.

Prior to recommissioning, observe the following:

- Make sure that all maintenance work has been carried out and completed in accordance with the data and information given in these instructions.
- Make sure that no unauthorised persons stay in the danger zone.
- Make sure that all covers and safety devices have been installed and are working properly.

NOTICE



DANGER



For recommissioning, please refer to the relevant manufacturer's documentation of the gas pressure regulator installed in the system, the work instructions of the system operator, and the remaining safety regulations of the system in which the safety relief valve has been installed.

To guarantee smooth operation, we recommend always keeping a maintenance set in reserve.

Note

6.3 Table of Screw Tightening Torques M_A

Item No.	R50 / Rp 1"	R50 / Rp 1 1/2"	R50 / Rp 2"
50	M6 / 8 Nm		
51	M6 / 8 Nm		

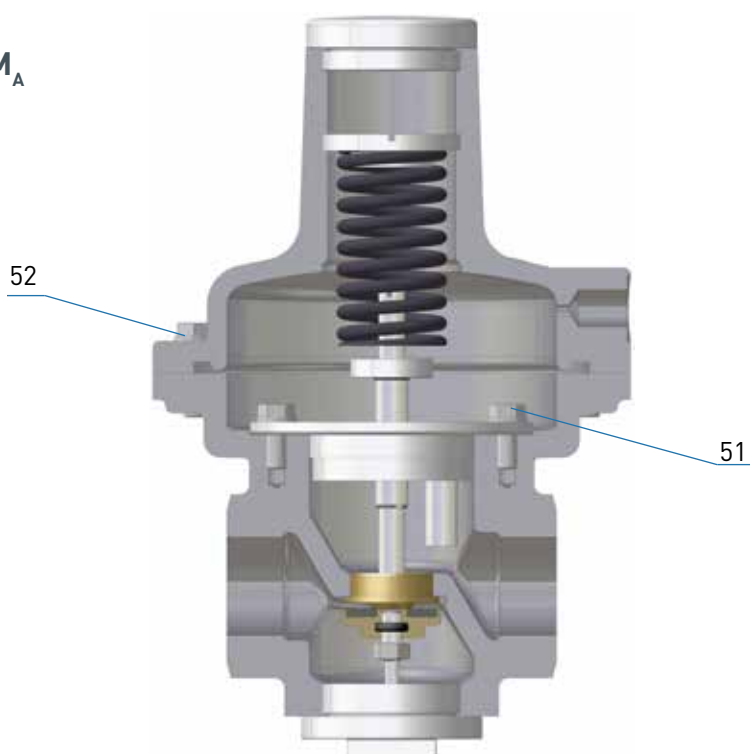

6.4 Lubricants Table

Components (apply a thin layer)	Lubricants	Article number
All O-rings	Syntheso Proba 270	SYNTHESO-PROBA-270
All fastening and locking screws	Anti Seize AS 450	AS 450

7 Troubleshooting

7.1 Safety Relief Valve

Description of the error	Possible cause	Elimination
SRV vents during operation	Actuator dirty or damaged	Check valve plate (seal) and valve seat for damage and dirt, replace valve plate, if necessary
	Static sealing elements defective	Replace O-rings
	Valve plate has become disconnected from the valve stem	Tighten nut under the valve plate
	Wrong SRV settings	Check SRV settings
	SRV set too low	Check SRV settings
	Sluggishness of the device due to dirt	Subject device to maintenance
SSV frequently shuts off	Stopcock upstream of SRV is closed	Open stopcock
	SSV set too low or SRV set too high	Check SSV and SRV settings
Gas escapes through breather line	Fastening of the main diaphragm has come off	Check diaphragm for fastening, damage and correct fit
	Main diaphragm is damaged or has been mounted incorrectly	

8 Replacement and Disposal

After the device has reached the end of its useful life, it must be dismantled and disposed of in an environmentally compatible manner.

During dismantling, components that may present a risk of injury by contamination, depending on the medium, are removed. Depending on the processed medium, the components must be properly decontaminated. Components capable of diffusion (diaphragm, O-ring, etc.) may have to be taken to a special disposal unit, depending on the medium used. If no return or disposal agreement has been reached, dismantled components should be recycled:

NOTICE



- Metals should be scrapped
- The remaining components should be disposed of after sorting according to material.

For technical information, please contact our customer service:

MEDENUS Gas-Druckregeltechnik GmbH	Phone +49 (0) 2761 / 82788-0	E-Mail info@medenus.de
Saßmicker Hammer 40	Fax +49 (0) 2761 / 82788-9	Internet www.medenus.de
D-57462 Olpe		

In addition, we are always interested in information and experience resulting from the application and which can be valuable for improving our products.

9 Spare Parts

9.1 Parts for Maintenance Work

O-Rings and Sealing Rings

Item no.	Name	Quantity pcs.	Exception	R50 / Rp 1" R50 / Rp 1 1/2" R50 / Rp 2"
4	O-ring	1		O-013
7	O-ring	1		O-006
11	O-ring	1		O-007
14	NBR-ring	2		N-001
17	O-ring	1		O-008
20	O-ring	1		O-013
		2	HD2	O-013
O-ring set order number:				OS-051

Valve Plate / Diaphragm

Item no.	Name	Number	R50 / Rp 1" R50 / Rp 1 1/2" R50 / Rp 2"
6	Valve plate	1	VT-012
16	Diaphragm	1	M-111

Example:

Gas pressure regulator: R50 / Rp1

Spare parts according to tables in 9.1

Valve plate:	VT-012
Diaphragm:	M-111
O-ring and sealing ring set:	OS-051

Info: The allocation of individual parts is done according to the item no. in the tables in 9.1, conforming to the spare parts drawings in 9.2.

9.2 Spare Parts Drawing R50

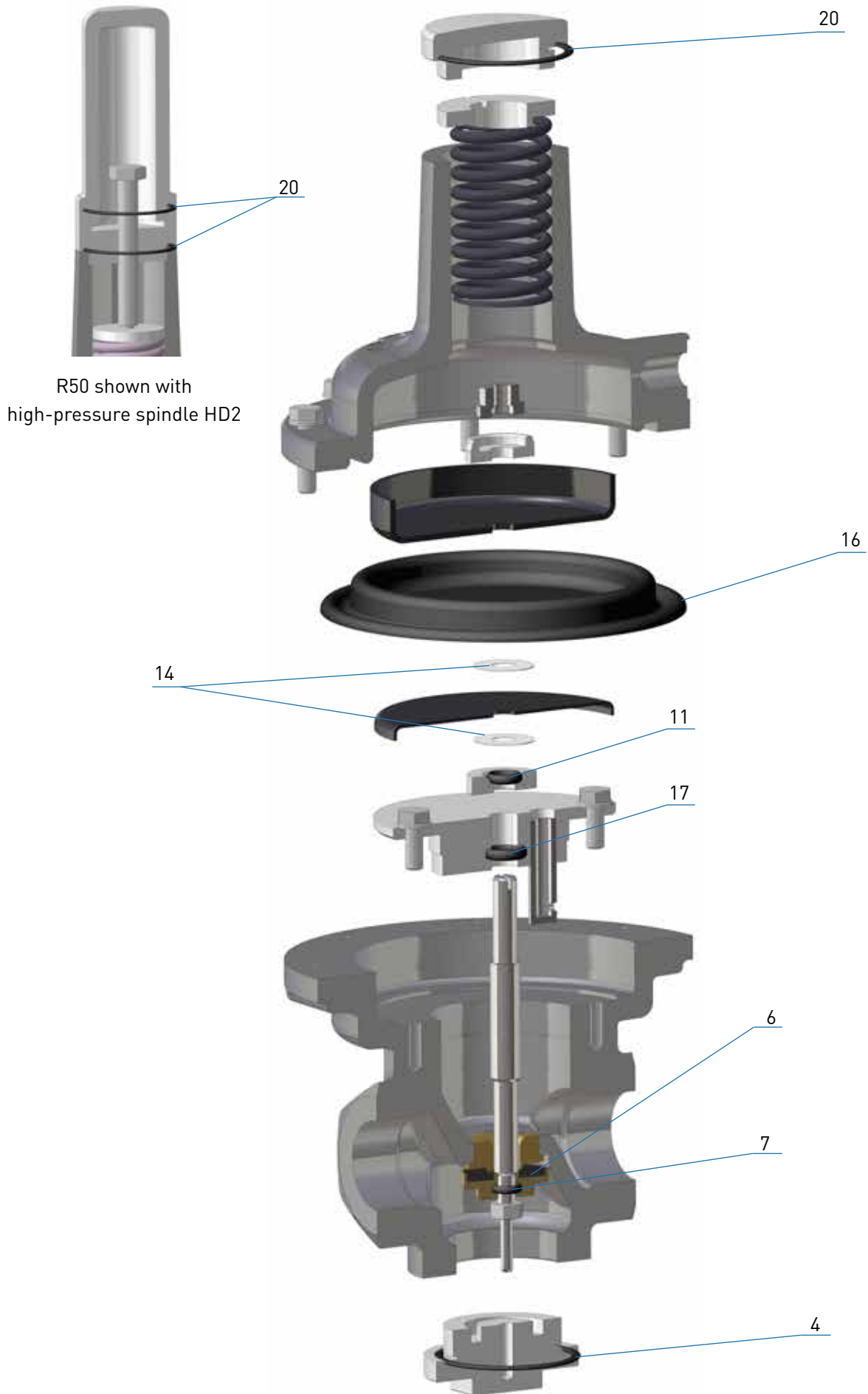

R50 shown with
high-pressure spindle HD2

Declaration of Conformity

(Summary)

Manufacturer: Medenus Gas-Druckregeltechnik GmbH

Address: Saßmicker Hammer 40
D-57462 Olpe-Saßmicke

herewith declares that the product:

R50 Safety shut-off valve

has been subjected to an EC type examination.

For devices that additionally carry the CE mark,
an EC-type-examination certificate has been issued according to:

EU/97/23/EC A III B EC Pressure Equipment Directive

Test report: CE-0085 / REF 16/046/0002/131 (R 50)

The EC type-examination is based on the harmonized
directives:

EU/97/23/EC A III B (1997-05-29)

EU/1272/2008 (2008-12-16)

Marking (PIN) according to Gas Appliances Directive

CE-0085BS0420 Model R 50

Marking according to Pressure Equipment Directive



The quality assurance system (module D) is monitored
by the DVGW.

Olpe-Saßmicke,
2016-09-30

A handwritten signature in blue ink, appearing to read 'Martin Clemens', is written over a faint, light-colored signature line.

Martin Clemens
Managing Director



MEDENUS Gas-Druckregeltechnik GmbH

Tel. +49 (0)2761 82788-0

Fax +49 (0)2761 82788-9

Sassmicker Hammer 40 / D-57462 Olpe

info@medenus.de

www.medenus.de

EN