

MEDENUS

Gas Pressure Regulation



Cellular Gas Filter DF 100



Operating and Maintenance Instructions

EN

Table of Contents

1 General Information	4
1.1 Warranty and Liability	4
1.2 Symbols, Notes	5
1.3 Terms, Abbreviations	5
2 Safety Instructions	6
2.1 Hazards of Handling the Device	6
2.2 Personnel Requirements	6
2.3 Country-Specific Requirements	6
2.4 Handover of the Operating and Maintenance Instructions	6
2.5 Safety in Operation	7
2.6 What To Do in Case of Danger	7
3 Responsibility of the Operator	7
4 Transport, Storage and Packaging	8
4.1 Transport	8
4.2 Storage	8
4.3 Packaging	8
5 Mounting and Commissioning	9
5.1 Safety Instructions and Preparation	9
5.2 Mounting	9
5.3 Leakage Test (Test for External Leakage)	10
5.4 Initial Commissioning / Recommissioning	10
5.5 Decommissioning	10
6 Maintenance	11
6.1 Maintenance Plan	11
6.2 Maintenance Procedure	11
6.3 Table of Screw Tightening Torques M_A	13
6.4 Lubricants Table	13
7 Troubleshooting	13
8 Replacement and Disposal	13
9 Spare Parts	14
9.1 Spare Parts Drawing DF 100	14
9.2 Parts for Maintenance Work	14
O-Rings	14
10 Notes	15
11 Declaration of Conformity	16

1 General Information

The personnel entrusted with installation, operation or maintenance of the cellular gas filter must have completely read and understood beforehand the following documents:

- **Cellular Gas Filter DF 100 Product Information**
The product information contains technical data, dimensions and a description of the design and the mode of operation.
- **Cellular Gas Filter DF 100 Operating and Maintenance Instructions**
This document allows safe and efficient handling of the device and contains information on assembly, commissioning, maintenance, troubleshooting, and repair according to regulations.
It is an integral part of the scope of delivery of the device, must be kept in close proximity of the device and must be readily accessible to personnel at any time.
The basic requirement of safe operation is compliance with all safety instructions and guidelines specified in these instructions. Accordingly, the information and instructions must be observed when working on the device or on the gas line. In addition, the local occupational safety regulations and the general safety regulations for the application range of the device shall apply.
The figures in these instructions are provided for basic understanding and may differ from the actual design. The contents in these instructions are protected by copyright. They may be used as part of operating the device. Any other use and / or reproduction is not permitted without prior authorization by the MEDENUS Gas-Druckregeltechnik GmbH.

1.1 Warranty and Liability

Claims under warranty or liability for personal injury and material damage are generally void, **if** one or several of the following **conditions are not observed**:

- Work on the device during the warranty period may only be performed in consultation with the manufacturer
- Designated use of the device in accordance with the established conditions of use
- Proper installation, commissioning, operation and maintenance of the device
- Operation of the device with properly installed and functioning safety devices only
- Operating and maintenance instructions of the device or of the system
- Observance of the maintenance instructions
- Properly performed repairs
- Supply lines without defects
- The use of original MEDENUS® spare parts and lubricants listed in these instructions or
- Force majeure

It is generally prohibited

- to perform constructive modifications on the device
- to keep using the device despite the detection of a defect

1.2 Symbols, Notes

The instructions contain safety instructions marked with symbols to indicate possible consequences in case of non-observance:

This combination of symbol and signal word indicates a potentially hazardous situation which may result in light injuries, damage to the device, the breakdown of the system and material or environmental damage if not avoided.



NOTICE

This combination of symbol and signal word indicates an imminent hazardous situation, resulting in death or serious injuries if not avoided.



DANGER

This signal word highlights useful tips, recommendations, and information for efficient and trouble-free operation.

Note

1.3 Terms, Abbreviations

Terms and abbreviations are explained below:

DN	Nominal width
M_A	Screw tightening torque
MOP	Maximum operating pressure in a system
SBV	Safety relief valve

2 Safety Instructions

National accident prevention regulations and the system operator's safety regulations are not superseded by these operating and maintenance instructions and must be taken into consideration with priority (in Germany, see, among others, DVGW Code of Practice G 600, G 459/II, G 491 and G 495)

When performing work on the device, the current general and specific safety regulations must be observed.

The application limits of the device with respect to the medium, operating pressure and operating temperature can be found on the type plate affixed to the device or on the acceptance test certificate.

Using the device under different operating conditions must be agreed upon in consultation with MEDENUS Gas-Druckregeltechnik GmbH.

The mechanical components of the device do not have any potential ignition sources of their own nor any hot surfaces and are thus not within the scope of 2014/34/EU (ATEX). The electronic accessories used comply with the ATEX requirements.

2.1 Hazards of Handling the Device

MEDENUS® devices conform with current standards and directives, the recognized technical rules, and the recognized safety rules.

However, improper use can result in hazards to the user or to third parties. This can also result in damage to the device or to the system.

This is why the device may only be used:

- in accordance with its designated use
- in perfect condition
- while observing the notes given in these operating and maintenance instructions, and inspection and maintenance regulations, which apply to the functioning and safety of the overall system.

Malfunctions or faults must be eliminated immediately.

2.2 Personnel Requirements

The device may only be mounted by qualified personnel.

Only authorised personnel in possession of the required qualification is allowed to perform settings or repairs on the device.

2.3 Country-Specific Requirements

The rules and regulations applicable at the place of use with respect to:

- gas lines, installation of the gas system
- gas supply
- work on the gas system
- accident prevention must be observed and complied with.

2.4 Handover of the Operating and Maintenance Instructions

The supplier of the system shall hand over these operating and maintenance instructions to the operator of the system no later than during commissioning and training of the operating personnel with the reminder to carefully store these instructions.

2.5 Safety in Operation

The device may only be used when all protective devices on the device or in the system are fully functional.

At least once a year, the device must be inspected for externally visible damage and for proper functioning by a representative of the manufacturer or by a qualified person.

A more frequent inspection may become necessary, depending on the system conditions.

2.6 What To Do in Case of Danger

Information on what is to be done in case of danger and in case of accidents can be found in the respective operator's or specialist company's work instructions.

3 Responsibility of the Operator

Operator An operator is a person who operates the device himself for commercial or economic purposes or hands it over to a third party for use / application and is legally responsible for the safety of the user, personnel or third parties.

Operator's obligations The device is used in the industrial sector. Accordingly, the operator of the device is subject to the legal obligations concerning occupational safety. In addition to the safety instructions contained in these instructions, the established maintenance intervals must be observed, taking into account the respective national standard (alarm and hazard prevention plan).

In particular, the following applies:

- The operator is obliged to perform work on MEDENUS® devices during the warranty period only after consultation with the manufacturer. Otherwise the claims under warranty will become void.
- The operator must obtain information on the current occupational safety regulations and determine additional hazards resulting from the special work conditions at the place of use of the device in a risk assessment. The operator must implement them in the form of operating manuals for operating the device.
- During the entire time of use of the device, the operator must check whether the operating manuals drawn up by him conform to the current state of the regulations and, if necessary, adapt them.
- The operator must clearly regulate and define the responsibilities for installation, operation, troubleshooting, maintenance, and cleaning.
- The operator must ensure that all persons handling the device have read and understood these instructions. In addition to that, he must train the personnel at regular intervals and inform it about the dangers.
- The operator must make available to the personnel the required protective equipment and oblige them to wear the required protective equipment.
- Moreover, the operator is responsible for the device always being in technically perfect condition.

Therefore, the following applies:

- The operator must make sure that the maintenance intervals described in these instructions are observed.
- The operator must have all safety devices checked regularly for functioning and completeness.

4 Transport, Storage and Packaging

4.1 Transport

Note

The device is delivered with flange protective caps. They must be removed prior to installation. Make sure that the device is transported horizontally using suitable lifting gear. The device must be handled carefully and secured against impact and shock. In case of transport damage, we will require the following information from the type plate affixed to the device:

- Type of device
- Device model
- Year of construction / fabrication number

4.2 Storage

Equipment and spare parts must be stored under the following conditions:

- Do not store outdoors.
- Store in a dry and dust-free location.
- Store on a flat surface.
- Do not expose to aggressive media.
- Do not expose to ozone or ionizing radiation.
- Do not store adjacent to direct heat sources.
- Avoid mechanical vibrations.
- Storage temperature: 0 to 25°C.
- Relative humidity: < 55 %.

Spare parts:

- Components susceptible to corrosion must be provided with a suitable preservative.
- Do not store O-rings and seals for more than 7 years even if stored properly.
- Spare parts must be stored in their original packaging until use.

Storage period for devices:

- Storage of the device for up to one year:
Store the cellular gas filter in its original packaging and original condition at the time of supply. All protective caps of the device must remain mounted.
- Storage of the device for more than 1 year (e.g. as a spare device):
Store the device in its original packaging and original condition at the time of supply and check it for damage once a year. Check the housing surface for dirt, damage and corrosion. If necessary, clean all external parts. After 7 years, all O-rings and seals must be replaced.

4.3 Packaging

- The individual packaged items have been packaged in view of the transport conditions to be expected.
- The symbols on the packaging must be observed during transport and storage.
- Only environmentally-friendly materials have been used for packaging.
- The packaging is designed for protecting the individual components from transport damage, corrosion and other damage until mounting. This is why the packaging must not be destroyed and only be removed just prior to mounting.

5 Mounting and Commissioning

5.1 Safety Instructions and Preparation

Prior to starting work on pressurised components:

- Close all connections to the gas line.
- Depressurise all pressurised components. Also discharge residual energies.
- Defective components that are subject to pressure in operation must be replaced immediately by a suitable qualified person.

DANGER



Prior to starting work, ensure sufficient clearance for mounting.

Before installing the device, check whether the performance data (type plate) and the scope of delivery coincide with the order or the system data, i.e., make sure that the provided devices are suitable for their intended purpose. In particular, the inlet pressure of the system must be lower than the maximum allowable pressure of the device.

Note

A direct contact of gas valves and fittings, i.e., the control system, with hardening masonry, concrete walls or floors is not allowed. Provide suitable supports, working materials, and protective equipment. Take into account the minimum clearances for maintenance as stated in the product information. Before installing the device in the pipeline, check whether a shut-off device that interrupts the gas flow supply to the device has been mounted upstream and downstream of the device to be installed.

Note

Prior to commissioning, make sure that all installation work has been carried out and completed in accordance with the data and information given in these instructions and that no unauthorised persons stay in the danger zone.

DANGER



5.2 Mounting

Remove packaging and protection from the connection flange surfaces.
Install the device without twisting the pipeline.

Make sure to observe the direction of flow, i.e., the arrow on the housing must point in the direction of flow.

In installation positions other than horizontal, MEDENUS Gas-Druckregeltechnik GmbH must be consulted.

Note

The tightening torques of the flange connections and additional information are available in the DVGW GAS Information Bulletin No. 19 (Flanged Connections in Gas Installations).

Note

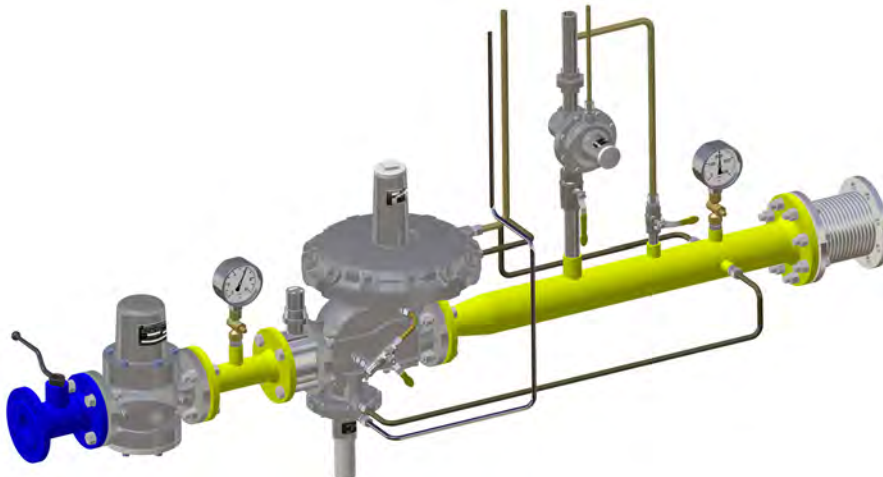

5.3 Leakage Test (Test for External Leakage)

The devices are subjected to a strength and leakage test ex works at MEDENUS Gas-Druckregeltechnik GmbH.

The leakage test in the fully assembled system must be performed prior to commissioning and following maintenance work.

For the external leakage test in the fully assembled system, the following applies:

For Germany:

According to DVGW Code of Practice G 491, the fully assembled system must be subjected to a leakage test with air or an inert gas at the installation site, using 1.1 times the maximum operating pressure of the system (MOP).

An exception is the room between the actuator of the gas pressure regulator installed in the system and the first shut-off valve on the outlet side. This room must be checked using a test pressure corresponding to the maximum possible setpoint of the gas pressure regulator. In this test, all detachable connections must be checked using a foaming agent.

For other countries:

The relevant national and international standards shall apply.

Procedure

- Close the ball valve upstream of the valves and fittings.
- Close the downstream shut-off devices (ball valves, solenoid or pneumatic valve).
- Depressurise the system.
- If the test pressure is higher than the relief pressure of the safety relief valve (SRV), the line upstream of the SRV must be closed.
- Connect the testing device to measuring points upstream and downstream of the gas pressure regulator.
- Always increase the test pressure slowly and steadily.

While doing so, you must ensure:

Pressure in outlet chamber \leq pressure in inlet chamber
Pressure build-up always from the inlet side (inlet chamber)
Pressure reduction always from the outlet side (outlet chamber)

Note

- After leakage test:
Open the ball valve in the SRV line again.



NOTICE

5.4 Initial Commissioning / Recommissioning

For commissioning, please refer to the relevant manufacturer's documentation of the gas pressure regulator installed in the system and the work instructions of the system operator.

5.5 Decommissioning

For decommissioning, please refer to the relevant manufacturer's documentation of the gas pressure regulator installed in the system and the work instructions of the system operator.

6 Maintenance

6.1 Maintenance Plan

The following sections describe the maintenance work required for optimal and trouble-free operation of the device.

If increased wear is detected during regular inspections, the required maintenance intervals must be shortened in accordance with the actual wear.

For any questions on maintenance work and intervals, please contact the manufacturer.

The intervals for monitoring and maintenance work are strongly dependent on the operating situation and the condition of the gas. This is why no fixed intervals can be given. For Germany, it is recommended to initially observe the maintenance periods according to the data given in the DVGW Code of Practice G 495. For each system, this must be followed by determining the maintenance interval independently on a medium-term basis.

During maintenance work, the components must be cleaned and subjected to a thorough visual inspection. This is also necessary if irregularities in the operating behaviour have been detected during operation or during functional tests. The check must cover in particular the filter insert and the seals.

Damaged parts and O-rings dismantled during dismantling must be replaced with new ones. The item numbers mentioned in chapter 6.2 (Maintenance Procedure) correspond to those listed in the spare parts drawings and spare parts lists.

It is recommended to stock the parts listed in chapter 9.5 on page 18 for maintenance work.

Interval	Maintenance activities	Personnel
When required	Replacing the filter cartridge	Qualified person
	Replacing the O-ring between the cover and the housing	
	Replacing the O-ring for sealing the filter cartridge	
	Replacing the O-ring for sealing the valve seat	
	Replace the O-ring between the hood / spacer and the housing	
	Replacing the O-ring between the hood and the spacer	
	Replacing the sealing of the connection of the differential pressure device	

6.2 Maintenance Procedure

If components have been removed, make sure they are mounted correctly, reinstall all fastening elements and observe the screw tightening torques.

Prior to recommissioning, observe the following:

- Make sure that all maintenance work has been carried out and completed in accordance with the data and information given in these instructions.
- Make sure that no unauthorised persons stay in the danger zone.
- Make sure that all covers and safety devices have been installed and are working properly.

NOTICE



DANGER



For recommissioning, please refer to the relevant manufacturer's documentation of the gas pressure regulator installed in the system, the work instructions of the system operator, and the other safety regulations of the system in which the filter has been installed.

6.2 Maintenance Procedure

Note As a functional test, a pressure loss measurement for the flow resistance can be carried out. Limit value for a contaminated filter cartridge: 0.8 to 1 bar

- Close fittings upstream and downstream of the filter. Depressurise the filter.
- Dismount the hood. To do so, unscrew the Allen screws on the hood. Exception for DN 25: Unscrew the hood.
- Remove O-ring (item 8) inside the housing or hood. Clean the O-ring groove and insert a new greased O-ring into the groove.
- Pull out the filter cartridge towards the top and check whether it is dirty. If necessary, the filter cartridge must be cleaned or replaced.
- For DN 150 / DN 200: Dismount the spacer. To do so, unscrew the Allen screws (item 55) at the spacer. Remove the O-ring (item 8) from the housing or from the spacer.

Note To lower the dismounting dimension for the nominal widths of DN 150 and DN 200, the filter cartridge and the spacer should be removed together.

- Clean the O-ring grooves and insert new, greased O-rings into the grooves.
- Dismount the cover. To do so, unscrew the Allen screws (item 52) from the cover. It may be necessary to clean the cover.
- Remove the O-ring (item 4) from the housing. Clean the O-ring groove and insert a new greased O-ring into the groove.
- Remount the cover. To do so, screw down the Allen screws (item 52) at the cover crosswise, using a torque wrench. (see table 6.3)
- Place the cleaned or new filter cartridge in the valve seat. The filter cartridges DN 25 and DN 100 comprise a centring ring at one end guaranteeing the correct fit of the cartridge in the valve seat. During installation, the centring ring is located at the bottom inside the filter.
- For DN 150 / DN 200: Mount the spacer. To do so, screw down the Allen screws (item 55) at the spacer crosswise, using a torque wrench. (see table 6.3)

Note To lower the mounting dimension for the nominal widths of DN 150 and DN 200, the filter cartridge and the spacer should be inserted together.

- Place the hood and tighten the Allen screws (item 50) crosswise, using a torque wrench. Exception for DN 25: Screw in the hood (item 50) and tighten it, using a torque wrench. (see table 6.3) When screwing in, exert a slight pressure on the hood. The filter cartridge is oversized and, due to the leak tightness to be achieved, it must be slightly compressed.
- The maintenance parts in the differential pressure measuring instrument are only replaced when necessary.
- Open the valves and fittings upstream and downstream of the filter and check for leak tightness (using a foaming agent).

Note To guarantee smooth operation, we recommend always keeping a maintenance set in reserve.

6.3 Table of Screw Tightening Torques M_A

Item No.	DF100 / 025	DF100 / 050	DF100 / 080 DF100 / 100	DF100 / 150	DF100 / 200
50				M12 / 62 Nm	M10 / 36 Nm
52	M8 / 18 Nm	M10 / 36 Nm	M10 / 36 Nm	M12 / 62 Nm	M12 / 62 Nm
55		M10 / 36 Nm	M8 / 18 Nm	M12 / 62 Nm	M10 / 36 Nm

The screw positions are indicated on page 14.

6.4 Lubricants Table

Components (apply a thin layer)	Lubricants	Article number
All O-rings	Syntheso Proba 270	Syntheso Proba 270
All fastening and locking screws	Anti Seize AS 450	AS-450

7 Troubleshooting

Description of the error	Possible cause	Elimination	Personnel
Differential pressure across the filter too high	Filter cartridge dirty	Replace filter cartridge	Qualified person
Dust in the system	Filter cartridge defective	Replace filter cartridge	
	O-ring damaged	Replace O-ring	
Leakage towards the outside	O-ring damaged	Replace O-ring	
Faulty differential pressure display	Pressure gauge or Reed contact defective	Replace pressure gauge* or Reed contact	

8 Replacement and Disposal

After the device has reached the end of its useful life, it must be dismantled and disposed of in an environmentally compatible manner. During dismantling, components that may present a risk of injury by contamination, depending on the medium, are removed. Depending on the processed medium, the components must be properly decontaminated. Components capable of diffusion (filter cartridge, O-ring etc.) may have to be taken to a special disposal unit, depending on the medium used.

If no return or disposal agreement has been reached, dismantled components should be recycled:

- Metals should be scrapped
- The remaining components should be disposed of after sorting according to material.

NOTICE



For technical information, please contact our customer service:

MEDENUS Gas-Druckregeltechnik GmbH
Im Langen Feld 3
D-57462 Olpe

Phone +49 (0) 2761 / 82788-0
Fax +49 (0) 2761 / 82788-9

E-Mail info@medenus.de
Internet www.medenus.de

In addition, we are always interested in information and experience resulting from the application and which can be valuable for improving our products.

*) If the connection lines are equipped with ball valves, the pressure gauge can be replaced during operation.

9 Spare Parts

9.1 Spare Parts Drawing DF 100

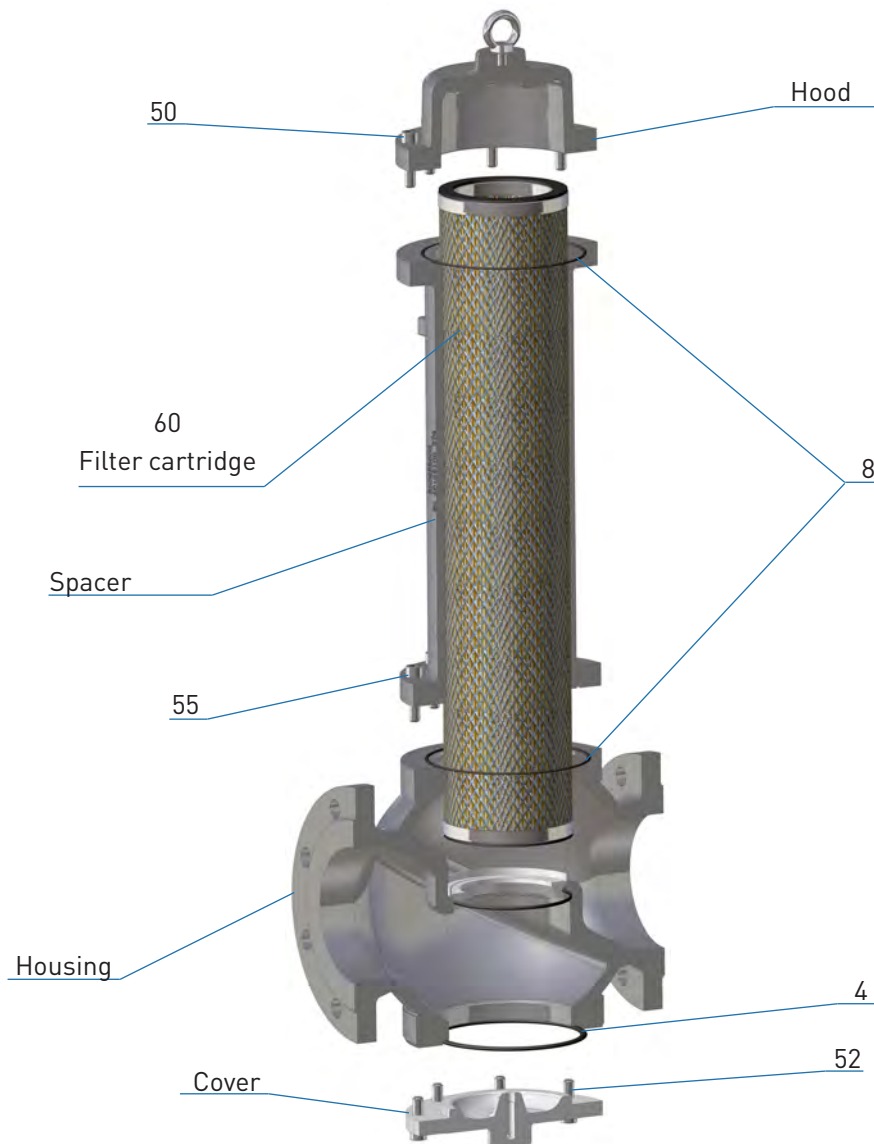

9.2 Parts for Maintenance Work

O-rings

DF 100 DN 150
shown

Item no.	Name	Quantity pcs.	DF100 / 025	DF100 / 050	DF100 / 080	DF100 / 100	DF100 / 150	DF100 / 200
4	O-ring	1	O-014-T	O-036-T	O-036-T	O-044-T	O-045-T	O-045-T
8	O-ring	1	O-016-T	O-021-T	O-023-T	O-027-T		
		2					O-030-T	O-041-T
O-ring set order number:			OS-041	OS-042	OS-043	OS-044	OS-045	OS-046

Filter cartridge

Item no.	Name	Quantity pcs.	DF100 / 025	DF100 / 050	DF100 / 080	DF100 / 100	DF100 / 150	DF100 / 200
60	Filter cartridge	1	FP-101	FP-102	FP-103	FP-104	FP-105	FP-106

10 Notes

A series of 20 horizontal dotted lines for writing notes.

Declaration of Conformity

Manufacturer: Medenus Gas-Druckregeltechnik GmbH
Address: Im Langen Feld 3
D-57462 Olpe

herewith declares that the product:

DF 100 Cellular Gas Filter

have been subjected to an EC-type examination
and conform to the basic requirements of the directives
GAR (EU) 2016/426 EC-Gas Appliances Regulation and
2014/68/EU A III B EC-Pressure Equipment Directive in the respective current version.

Test reports: CE-0085 / AZ 17/346/4356/210
CE-0085 / AZ 14/108/4501/121

The EC type examination is based on the harmonized European Standards
and/or national standards as well as the European directives and / or regulations:

2014/68/EU A III B EC Pressure Equipment Directive (15.04.2014)
GAR (EU) 2016/426 A III B EC Gas Appliances Regulation (09.03.2016)

Marking (PIN) according to Pressure Equipment Directive and Gas Appliances Regulation

CE-0085CP0531 model DF 100

CE-0085

The quality assurance system (module D) is monitored by the DVGW.

Registration No. Pressure Equipment Directive **SD-0085BQ0510**

Registration No. Gas Appliances Regulation SE-0085BQ0510

Olpe,
01.09.2020



Alexander Christiani
Managing Director

In the download area of our homepage, this document is available in different languages. You can use the following QR codes and links to go directly to the corresponding documents.



Deutsch:

http://medenus.de/files/upload/downloads/DF100/BWA_DF100_de.pdf



Englisch:

http://medenus.de/files/upload/downloads/DF100/BWA_DF100_en.pdf



MEDENUS Gas-Druckregeltechnik GmbH

Tel. +49 (0)2761 82788-0

Fax +49 (0)2761 82788-9

Im Langen Feld 3 / D-57462 Olpe

info@medenus.de

www.medenus.de

EN