

MEDENUS

Gas Pressure Regulation



Gas Pressure Regulator R 51

Product Information

EN

Table of Contents

Application, Features , Technical Data	4
Application	4
Features	4
Type of model (options)	4
Technical Data	4
Design and function	5
Option	6
K_G^* value and diaphragm assemblies	6
Diaphragm assembly setpoint spring table	6
Dimensions, connection and weight	7
Dimensions and weight	7
Dimensional drawing	7
Connection of test leads and breathing lines	7
Ordering data	9
Contact	10
Notes	12-14

List of abbreviations and formula symbols

AC	accuracy class	PS	maximum allowable	SG	closing pressure class
HPS	high-pressure screw spindle		pressure	t_u	inlet gas temperature
K_G	values	p_u	inlet pressure	VS	valve seat
p_d	outlet pressure	Q_n	standard volumetric flow rate	w_d	outlet gas velocity
p_{ds}	setpoint of outlet pressure	DA	diaphragm assembly	w_u	inlet gas velocity
		BV	breather valve	ρ_n	gas density

*) K_G value for natural gas

Application, Features , Technical Data

Application

Gas pressure regulator (GPR) direct-acting, (working without power supply), for installations according to DVGW - Code of Practice G 491 (A) and G 600 (A) (TRGI)

Particularly suitable for dynamic regulating lines (e.g. gas firing installations, burner circuits, gas-powered operation).

Can be used as an equipment component for gas consumption systems according to Regulation (EU) 2016/426.

For use for gases according to DVGW - Code of Practice G 260 / G 262 and neutral non-aggressive gases.

(other gases on request)

Features

- Integral flameproof design (IS)
- diaphragm assembly with internal or external measuring line

Type of model (options)

- Oxygen model ($p_u \leq 10$ bar)
- with BV breather valve

Technical Data

Type	R 51	Gas pressure regulator	
Model	Integral Pressure resistant (IS)	Accuracy class	
Maximum allowable pressure PS	16 bar	AC and closing	
Max. gas inlet pressure $p_{u,max}$	16 bar	pressure class	
Nominal width	DN 25	SG at the out-	
Connection type	DIN - flanges PN 16 (ASME flanges upon request)	let pressure	
Material		range p_d	
Housing / actuator housing	Al cast alloy*	requirement	
Temperature range class 2 (Operating / ambient temperature)	-20 °C bis +60 °C	-20°C to 60°C	AC SG
Closing pressure class	SZ 2,5	50 mbar up to 100 mbar	up to 10 up to 20
Function, strength and density	DIN EN 334	> 100 mbar up to 500 mbar	up to 5 up to 10
CE mark according to PED/ PIN number	CE-0085-CR0137	> 500 mbar	2,5 5

Ex protection The mechanical components of the device do not contain any potential ignition sources of their own; thus, they do not fall under the scope of ATEX 95 (94/9/EC). The electrical components of the device comply with ATEX requirements.

*) Corrosivity category according to DIN EN ISO 12944-2.
The categories C1 to C5-I including guaranteed without additional coatings.
For the category C5-M a coating with epoxy resin is recommended.



Application, Features , Technical Data

Design and function

The spring-loaded gas pressure regulator R 51 has the function of keeping the outlet pressure of a gaseous medium constant within allowable limit values, independently of the effect of interferences, such as changes in the inlet pressure and/or in the gas tap, in the connected regulating line on the outlet side. The gas pressure regulator is composed of the actuator housing and the „diaphragm assembly plus actuator“ functional unit.

The valve seat model is pre-pressure-compensated.

The gas flows through the actuator housing in the direction of the arrow. The internal or external measuring line connection is used to pass the outlet pressure to be regulated to the bottom of the diaphragm comparator of the diaphragm assembly. It compares the actual value with the command variable preset by the force of the setpoint spring. The setpoint required in each case is set via the setting screw. Any deviation from the setpoint is transmitted by the valve stem to the actuator, which is adjusted such that the actual value is adjusted to the setpoint.

In case of zero tap, the actuator will close tight, causing the closing pressure to be established.

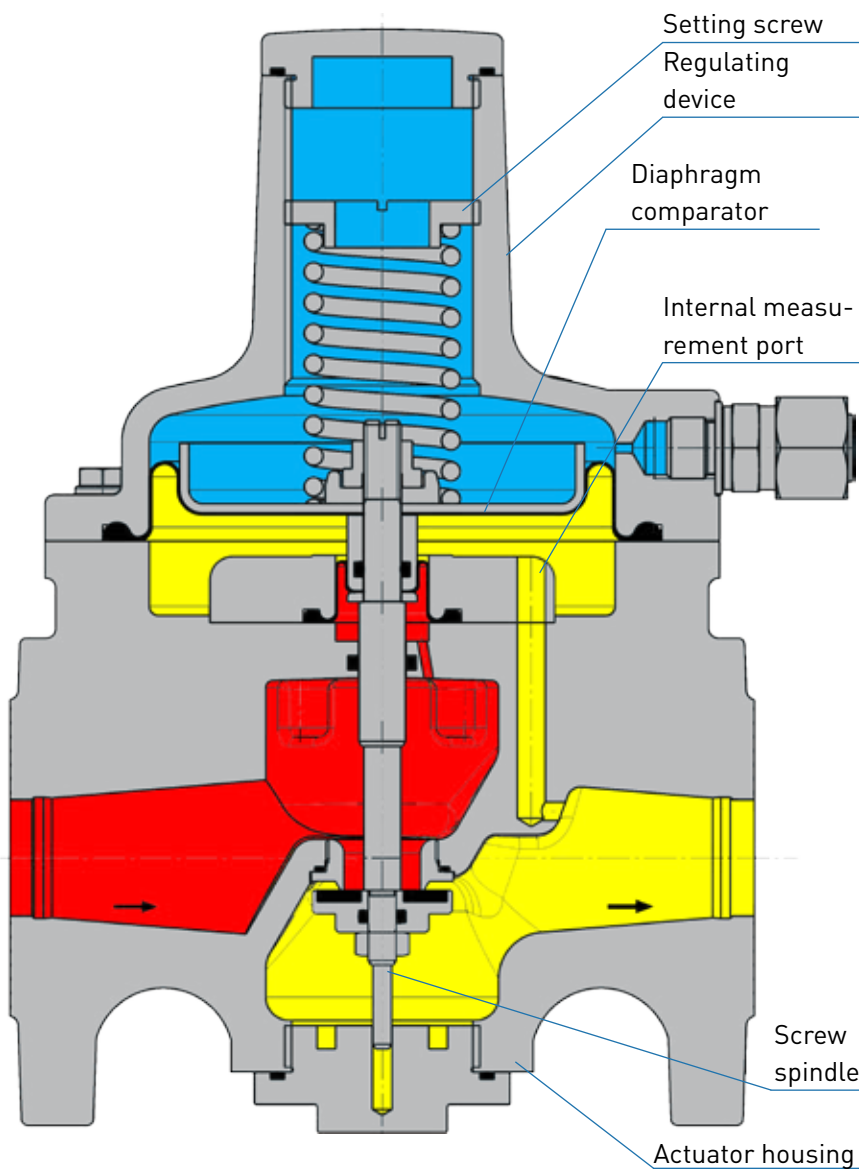

Option: external impulse tap

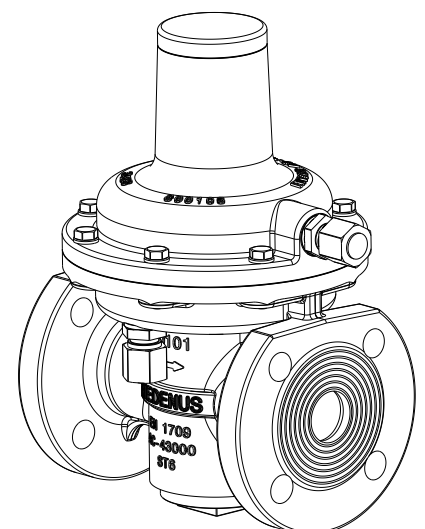

Option

Breathing valve BV

The breathing valve BV serves to protect the room of installation against inadmissible gas leakage from the venting space of safety shut-off valves.

It is also an alternative to the cost- and work intensive installation of breathing pipes.



Breathing valve BV

Application, Features , Technical Data

K_G^* value and diaphragm assemblies

Nominal width	Valve seat \varnothing (mm)	K_G^* value ((m ³ /h)/bar)	Diaphragm assembly \varnothing (mm)
DN 25	16,5	175	160

Diaphragm assembly setpoint spring table

Diaphragm assembly \varnothing (mm)	Spring data		
	Spring no.	Wire \varnothing [mm]	Colour [RAL]
160			
26 - 50	FG100	2,0	9005
50 - 90	FG101	2,3	5015
75 - 165	FG102	2,6	6018
130 - 345	FG103	3,2	3020
220 - 670	FG104	4,0	5010
525 - 1185	FG105**	4,5	6010
850 - 2070	FG106***	5,3	7035
1580 - 3900	FG107***	6,0	1028

*) K_G value for natural gas: $d = 0.64$ ($\rho_n = 0.83$ kg/m³), $t_u = 15^\circ$ C and external measurement port. With an internal measuring line, the maximum AC flow rate is limited to 100 ³/h.

**) with high-pressure spring plate (HD1)

***) with high-pressure screw spindle (HD2)

Dimensions, connection and weight

Dimensions and weight

Nominal width DN	RE (mm)	A (mm)	B (mm)	L (mm)	HD2 (mm)	X (mm)	Weight (kg)	Weight HD2 (kg)
25	160	178	59	160	112	180	3,6	0,4

Dimensional drawing

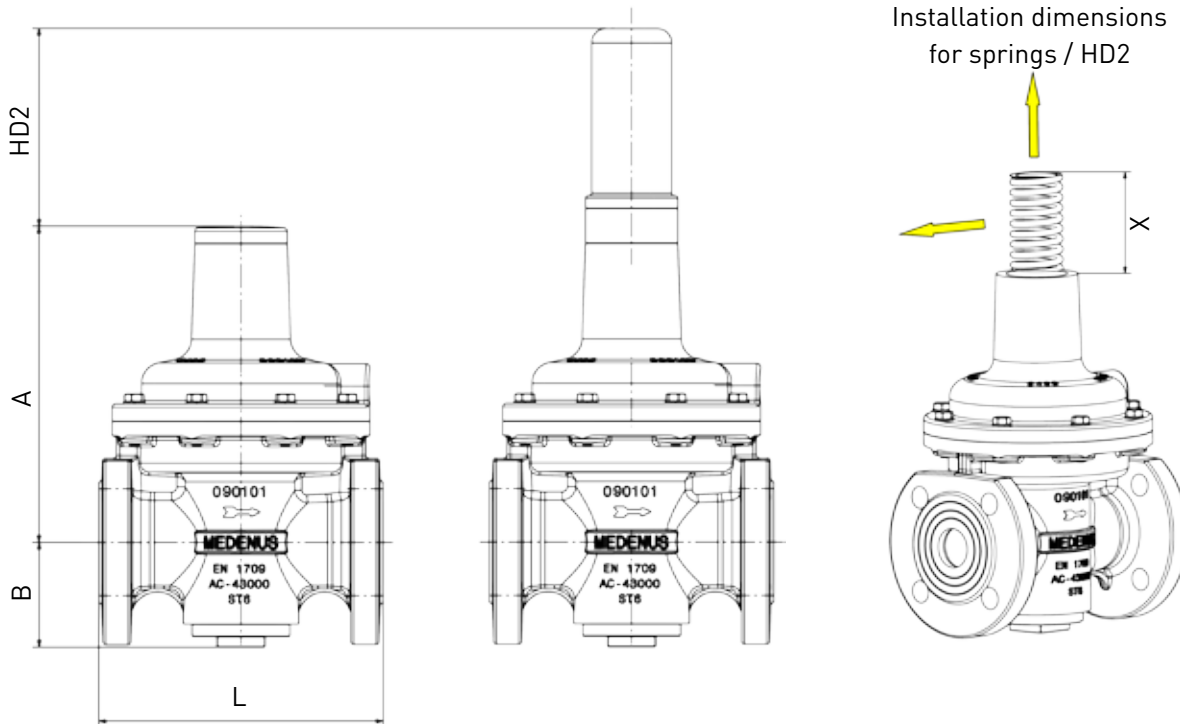

Example:

R51/025/160 with HD2

Weight (Regulator + HD2): 3,6kg + 0,4kg = 4kg

Dimensions (A + HD2): 178mm + 112mm = 290mm

Connection of test leads and breathing lines

Nominal width	Regulating device	
	external measuring line	breathing line
DN 25	Connection* for: Pipe 10 x 1.5 (G 1/4)	Connection* for: Pipe 10 x 1.5 (G 1/4)

Note

For installation, start-up and maintenance, the following documents must be observed:

DVGW - Code of Practice G 491 and G 600

Operating and Maintenance Instructions R 51

The gas pressure regulators R 51 shall be installed in the pipeline preferably in horizontal position with vertical position of the diaphragm assembly spring cap. For all nominal widths, the direction of flow is indicated by an arrow on the housing.

*) Pipe connections according to DIN EN ISO 8434-1 (DIN 2353)

Design

Calculation of the required K_G value

The standard flow value for a completely open actuator ($p_u = 2 \text{ bar}$; $p_d = 1 \text{ bar}$) corresponds to the K_G value.

The K_G value refers to natural gas of density 0.83 kg/m^3 at 15°C . For other gases, a flow rate equivalent to that of natural gas is to be expected.

$$Q_{n \text{ natural gas}} = Q_{n \text{ gas}} / \sqrt{(0.83 / \rho_{n \text{ gas}})}$$

$$p_d / p_u > 0,5$$

K_G value at a subcritical pressure ratio

$$K_G = Q_n / \sqrt{p_d \cdot (p_u - p_d)}$$

$$p_d / p_u \leq 0,5$$

K_G value at a supercritical pressure ratio

$$K_G = 2 \cdot Q_n / p_u$$

Note: all calculated pressures are absolute pressures.

Device selection

The device is selected on the basis of its K_G value from the table of flow rate coefficients (page 6)

Note: For spring-loaded devices, a capacity reserve of 10-20 % is recommended in order to comply with the accuracies given.

Checking the gas velocities

$$w = 380 \cdot Q_n / (DN^2 \cdot p_{abs})$$

Note: The factor 380 refers to an operating or gas temperature from approx. 15°C to 20°C . For other temperatures, the velocity must be corrected as follows: $w_{korr} = w \cdot (t_{gas} + 273.15) / 290$

Recommended max. gas velocity at the inlet flange :
 50 - 70 m/s Lower value for deflections upstream of the regulating valve,
 20 m/s for filters connected upstream

Recommended max. gas velocity at the outlet flange:
 100 - 200 m/s Lower value for reducing sound emission

Recommended max. gas velocity at the impulse tap: 15 - 25 m/s Lower value for outlet pressures below 100 mbar

Example:

$$\begin{array}{l} p_{u \text{ min}} \ 5,0 \text{ bar} \quad / \quad p_{u \text{ max}} \ 8,0 \text{ bar} \\ p_{d \text{ min}} \ 0,2 \text{ bar} \quad / \quad p_{d \text{ max}} \ 0,5 \text{ bar} \\ Q_{n \text{ min}} \ 150 \text{ m}^3/\text{h} \quad / \quad Q_{n \text{ max}} \ 200 \text{ m}^3/\text{h} \end{array}$$

$$1,5 \text{ bar} / 6 \text{ bar} = 0,25 < 0,5$$

→ supercritical pressure ratio

$$K_G = 2 \cdot 200 / 6 = 67 \text{ (m}^3/\text{h)/bar}$$

R 51 DN 25 VS 16,5
 K_G - value: 175 (m³/h)/bar

Inlet and outlet nominal width of the pipeline according to the selected device: 25 mm
 Selected widening of the outlet pipeline: 50 mm

$$w_u = 380 \cdot 200 / (25^2 \cdot 6) = 20 \text{ m/s}$$

$$w_d = 380 \cdot 200 / (25^2 \cdot 1,5) = 81 \text{ m/s}$$

$$w_{\text{Impuls}} = 380 \cdot 200 / (50^2 \cdot 1,5) = 20 \text{ m/s}$$

The device selected in the example of nominal width DN 25 can be operated under these conditions.

Note:

For a more detailed interpretation of our gas pressure control devices, the configurator is available on our homepage medenus.de. (Medenus.de/en/service/konfigurator.html)

Ordering data

Example:

Gas Pressure Regulator: R51/025/160/16,5/links/BV/ext/WAZ/So

		Order code:								
		R51	025	160	16,5	links	BV	ext	WAZ	So
Order selection	Title									
Type										
R51	R51	R51								
DN - Nominal width			025							
RE - Regulating device	160			160						
Valve seat diameter	16,5				16,5					
Flow direction										
right (from left to right)	-									
left (from right to left)	links					links				
Equipment										
without equipment	-									
Breathing valve	BV						BV			
Measuring line										
internal	int									
external	ext							ext		
Acceptance test certificate to EN 10204/3.1										
witout acceptance test certificate	-									
with acceptance test certificate	WAZ								WAZ	
Special version	So*									So

Only one option can be selected in each selection group.

So*) for example:

- Oxygen model ($p_u \leq 10$ bar)
- with Breather valve BV

Contact

If you want to know more about our products and services, please contact your local representative or visit our website at www.medenus.de/en.



Managing Director Alexander Christiani

Telephone: +49 (0) 2761 / 82788-18
Fax: +49 (0) 2761 / 82788-9
E-Mail: a.christiani@medenus.de



Field Sales Germany Jörg Pflugner

Mobile: +49 (0) 170 635 5309
Fax: +49 (0) 2761 / 82788-9
E-Mail: j.pflugner@medenus.de



Head of Sales & Marketing Franz Feichtner

Telephone: +43 (0) 7227 / 211-17
Fax: +49 (0) 2761 / 82788-9
Mobile: +49 (0) 151 / 51002711
E-Mail: f.feichtner@medenus.de



In-House Sales Maïke Rath

Telephone: +49 (0) 2761 / 82788-11
Fax: +49 (0) 2761 / 82788-9
E-Mail: m.rath@medenus.de



In-House Sales Jan Arens

Telephone: +49 (0) 2761 / 82788-20
Fax: +49 (0) 2761 / 82788-9
E-Mail: j.arenst@medenus.de



In-House Sales Stefanie Müller

Telephone: +49 (0) 2761 / 82788-13
Fax: +49 (0) 2761 / 82788-9
E-Mail: s.mueller@medenus.de

Worldwide Sales Agencies:
medenus.de/en/kontakt.html



MEDENUS Gas-Druckregeltechnik GmbH

Im Langen Feld 3
D-57462 Olpe
Fon: +49 (0)2761 82788-0
Fax: +49 (0)2761 82788-9
E-Mail: info@medenus.de
Internet: www.medenus.de



THE MEDENUS PLUS

10 reasons for good business relations

1. Consultancy expertise and quality standards developed over decades
2. Broad and proven standard range of feedback controllers
3. Modern, fast and efficient production for series products and for individual orders
4. Customized design of pressure regulators and vacuum regulators and special designs
5. Guaranteed deadline compliance with a delivery time guarantee
6. Fast response time in all matters
7. Sufficiently large parts storage for production and spare parts
8. Customized theory & practice training courses
9. Modular design right across the entire product range to facilitate optimized handling of spare parts
10. Made in Germany

Notes

A series of horizontal dotted lines for taking notes.

Notes

A series of horizontal dotted lines for writing notes.

In the download area of our homepage, different languages of this document are available.
You can use the following QR codes and links to go directly to this document in your language.



Deutsch:

http://medenus.de/files/upload/downloads/R51/Pi_R51_de.pdf



English:

http://medenus.de/files/upload/downloads/R51/Pi_R51_en.pdf



MEDENUS Gas-Druckregeltechnik GmbH

Fon +49 (0)2761 82788-0

Fax +49 (0)2761 82788-9

Im Langen Feld 3 / D-57462 Olpe

info@medenus.de

<http://medenus.de/en/>

EN